

Observations on the Doors and Windows in Byzantine Architecture*

Stavros Mamaloukos

I. It has been long clear among byzantinists that research on doors and windows is particularly important for the study of Byzantine architecture in general¹. Despite that, relevant attempts at studies of this subject are not only scarce, but, frequently, also inadequate. The majority of relevant studies examine the doors and windows somehow “iconographically” and not technically, as is the case with most aspects of Byzantine architecture. Hence, the usual practice is to study the main elevation of the opening and the form of some individual parts, such as the ornamentation on their frames and other marble members, while little or nothing is said about their structure.

The study of doors and windows in Byzantine architecture is beset with a multitude of difficulties. The most important among them are the fact that the original material is immense and scattered widely, as well as the fact that its documentation is particularly hard. A meticulous drawing survey (at least one plan, one section, and two elevations—internal and external—not to mention the required particular details) is absolutely necessary for the documentation. Additionally, the researcher must also carry out a meticulous technical analysis, often in conjunction with archaeological research, as the delicate original elements are often altered and decayed, making their reconstruction even harder. Another difficulty that arises not just in the study of this subject, but of Byzantine architecture in general, is the fact that the remaining monuments, though numerous, represent only a fraction of the architectural production of the period. Furthermore, the remaining monuments are disproportionately scattered over a wide geographic region, i.e. some regions may contribute hundreds of monuments, while others very few or none at all. Finally, research must necessarily focus on only certain kinds of buildings, mostly churches and fortifications, and in particular usually only on upscale monuments, whose quality of construction has contributed

* This paper has been first presented in the 27th Symposium of the Christianike Archaeologike Hetaireia on May 11th 2007 (Mamaloukos 2007). The present form of the paper is based on its final Greek version, under publication in the Volume in Honor of Professor Panagiotis Vocotopoulos. I extend my sincerest gratitude to NTUA Professor Manolis Korres, for his valuable remarks and suggestions, as well as to my friends and colleagues Dimitris Athanasoulis, Klimis Aslanidis, Ploutarchos Theocharidis, Michalis Kappas, Petros Koufopoulos, Stavroula Melissou, Marina Myriantheos, Giorgos Pallis and Aggeliki Mexia, who contributed decisively to my research by contributing material or voicing their thoughts during our discussions. Thanks are owed to the architect N. Koumantos for his help with the translation of the original Greek text into the English language.

¹ The importance attributed to the subject is demonstrated by the relevant research included in general synthetic studies such as Millet 1916, 202-213; Megaw 1931-1932, 120-128; Orlandos 1937, 67-71; id. 1994, 399-434; Vocotopoulos 1992, 159-68; Nikonanos 1979, 170-73; Ousterhout 1999, 151-56; Bouras and Boura 2002, 412-27; Mamaloukos 2005, 12-13, fig.6; and Athanasoulis 2006, see mainly 153-58, 268-72, 295-98, 313-15, 322-24, 377-79, 399-400, 476-90, and 525, as well as in monographs on individual monuments (Mamaloukos 1991, mainly 1116-1117 and Vocotopoulos 2000, see mainly 314, fig. 2-3,7).

to their preservation until today. It is, thus, easy to realize how such a small and disparate sample pool can lead to risky conclusions.

While existing bibliography includes numerous publications on the decoration of the marble or timber door-frames², the folds of the doors³, and the frameworks of the windows⁴, a handful of studies exist on the general structure and construction of doors and windows. In a sense, the study of such important structural details has gone largely unnoticed in the general effort to study the overall character and development of Byzantine architecture. The most systematic attempt at studying the doors and frames conducted in recent years is that of Charalambos and Laskarina Boura concerning church architecture in the 12th century Helladic region⁵. However, the aims of the study are broader, and the monuments studied are restricted to a small geographic area and timescale; hence, the breadth and depth of the study of the subject in question is necessarily limited. The doctoral dissertation of Dimitris Athanasoulis, on the Episkopi of Olena during the Mid and Late Byzantine Period, which makes good use of all the relevant bibliography, includes an excellent analysis on the doors and windows of churches in the area of Eleia, Peloponnese, followed by some astute general observations⁶.

The aim of the following study is, of course, not to completely cover this vast subject, an attempt that would anyway be futile without the systematic documentation and analytical study of the multitude of surviving samples. The aim is rather to extract some useful conclusions, and to put forth a novel way of examining the subject, through a review of known specimens, and the study of new material. This sort of study might help in categorizing and further analyzing Byzantine doors and windows, so that some conclusions might be gradually drawn, in order to offer insight into not only the subject in question, but into Byzantine architecture in general.

II. Before any attempt at a systematic study of matters pertaining to the structure, construction and form of openings, it is useful to make certain clarifications on matters of terminology, in order to avoid misinterpretations that might arise either through the use of inaccurate everyday terms, or because of the continuous development and increasing complexity of language. Thus, a door opening (άνοιγμα θύρας) or window opening (άνοιγμα παραθύρου) hence refers to an opening in a wall through which one enters into a residence or generally a covered, enclosed space⁷, and to an opening in a wall used to provide ventilation and lighting to an interior space⁸,

² Sklavou-Mavroeidi 1982-1983; Bouras and Boura 2002, 529-30; Drandakis 2002, sparsim.

³ Bouras 1964; Matthiae 1971; Bouras 1975; Bouras 1989-1990; Iacobini 2007; id. 2009.

⁴ Ousterhout 1999, 151-156; Bouras and Boura 2002, 427 and 531.

⁵ Bouras and Boura 2002, 412-27.

⁶ Athanasoulis 2006, see mainly 153-58, 268-72, 295-98, 313-15, 322-24, 377-79, 399-400, 476-90, and 525.

⁷ Orlandos and Travlos 1986, 130 (entry: θύρα). See as well Dimitrakos, 3389 (entry: θύρα).

⁸ Dimitrakos, 5433 (entry: παραθύριον). For the ancient Greek terms θυρίς (window) and παραθυρίς (= θυρίς, παραθυρίς) see Orlandos and Travlos 1986, respectively 131 (entry: θυρίς) and 198-199 (entry: παραθυρίς).

respectively. A doorframe (πλαίσιο του ανοίγματος θύρας, θύρωμα, περίθυρο, περιθύρωμα) or window frame (πλαίσιο του ανοίγματος παραθύρου)⁹ hence refers to the structure that frames the opening¹⁰. Concerning the Greek term κούφωμα (ξύλινο θυρόφυλλο ή παραθυρόφυλλο μετά του πλαισίου του), it must be noted that the Greek term refers both to doors and windows interchangeably; it implies that they are constructed of wood, and, moreover, it covers the whole structure set in an opening, i.e. both to the door-frame and window-frame, and to all moving parts, such as door folds, window casements, window-shutters, etc¹¹. For lack of such an all-encompassing term in English, the separate terms door and window will be used. A door case or window case (πλαίσιο του κουφώματος, κάσσα) hence refers to the timber, metal or other material structure that supports the door folds and window casements. Lastly, the term framework refers to a fixed structure that seals a window opening.

III. It is well known that Byzantine building craftsmanship and technology is largely based on patterns found in Roman architecture, through which it also inherited other building and construction patterns dating back to even more ancient times. The same seems to have happened in the case of doors and windows, which many times adhere, often astonishingly close, to antique patterns, not just Roman, but also Hellenistic and even Classical.

The door and window openings of ancient Greek and Roman architecture have been frequently studied, independently or in conjunction with other architectural elements, both from an analytical, as well as as, a systematic and synthetic viewpoint. At this point, one must commend three rather recent synthetic studies: that of René Ginouvès, Roland Martin and their associates¹² and that of Naif Haddad¹³, which include, along with a discussion on the subject, older bibliography and many illustrations, as well as that of Manolis Korres on the west doorway of the Parthenon, which contains some invaluable general commentary¹⁴. Based on these studies, one may briefly outline the different types of door openings along with the development of their form, construction and morphology from the very first ancient Greek era to the end of Roman times, and Late Antiquity as follows: (Fig. 1, Fig. 2).

The simplest, and arguably oldest type of door (Fig. 1A), was that of a simple opening in the wall, whose reveals were perpendicular to the wall faces. A second door type (Fig. 1B), mostly

For the ancient Greek terms παραθύρα (side door), παραθύριον (small side door) see as well Orlandos and Travlos 1986, 198 (entries: παραθύρα and παραθύριον).

⁹ On the related meaning and parallel use of the terms see Bouras and Boura 2002, 414 and 485, n. 207.

¹⁰ Dimitrakos, 4097 (entry: κούφωμα).

¹¹ Dimitrakos, 5845 (entry: πλαίσιον, 2).

¹² Ginouvès, Martin et al. 1992, 36-58, pl. 20-29 and mainly 37-39 (θύρα) and 39-42 (παραθύρο), for terms and a discussion on related subjects.

¹³ Haddad 1995.

¹⁴ Korres 1994, 41-67.

encountered also in the Classical and Hellenistic era, differed from the first in that the Doric or Ionic order door frame, timber or stone, did not extend through the width of the entire wall, but rather left a shallow recess on the interior. Into this recess fit the door folds, which could thus revolve a little over 90° to lie almost perpendicular to the interior face of the wall. In the third door type (Fig. 1Γ), which seems to have developed much earlier, since the Mycenaean era¹⁵, but spread widely in Roman times, a rather small protrusion was formed around the opening on the exterior, behind which the door folds were placed. This protrusion was either integral with the door frame, or took the form of an inset stone or timber frame.

As for the general form of windows, current research reveals the following: In earlier times, but also up to later years, secondary spaces and humble buildings had narrow, slit windows. Ground floor and first floor spaces had small or larger windows that were secured with iron gratings fixed to the window frame, and timber window casements. These windows differed little from the

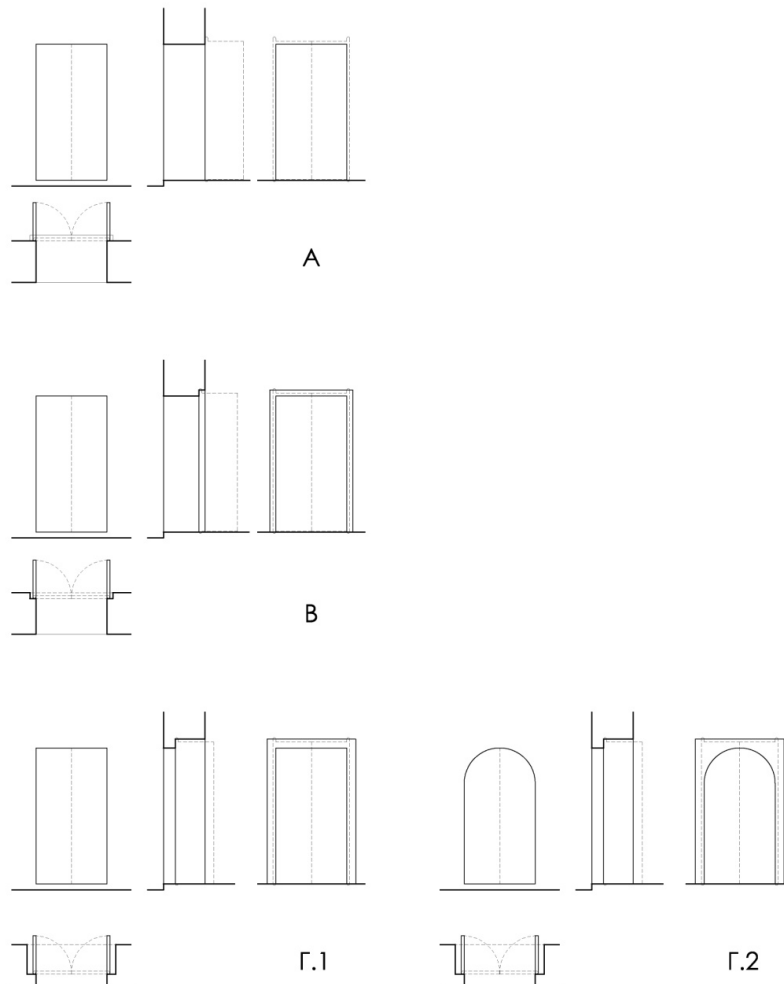

Fig. 1: Typology of door openings in ancient Greek and Roman architecture.

¹⁵ The Gate of the Lions in Mycenae is a characteristic example.

doors in their structure and form. Double-light windows are of particular interest, as they are windows with two openings separated by a mullion. Again a relatively narrow protrusion was formed on the exterior face, behind which lay the window casements. Windows that did not possess opening casements were secured with iron gratings or with frameworks.

IV. Based on available sources one can conclude that the most common door type in Byzantine architecture was that in which a rather small protrusion was formed around the door opening on the exterior, behind which the door folds were placed (Fig. 1Γ). There is no doubt that this

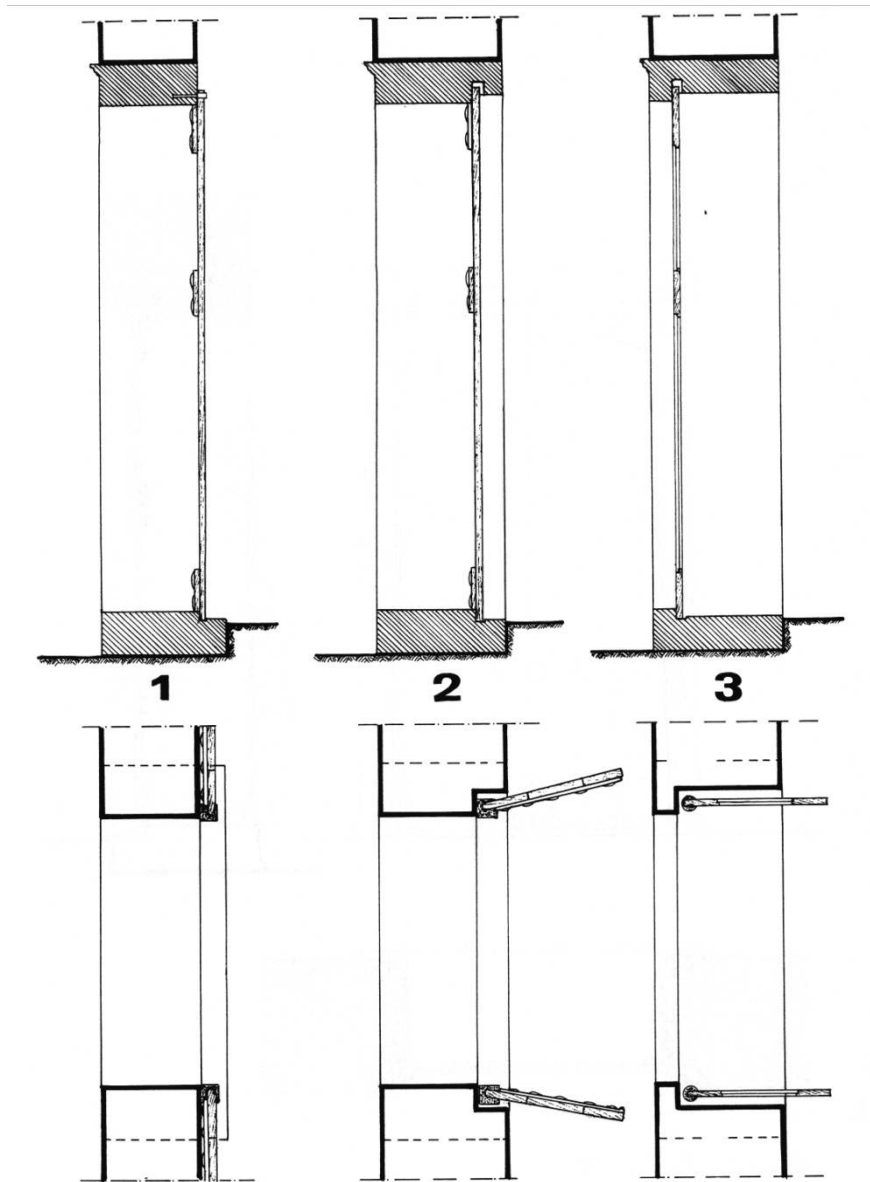

Fig. 2: Types of door openings in ancient Greek and Roman architecture (Haddad 1995, pl. 91).

type is a continuation of the type Γ, which originated in ancient times and was widely disseminated in Roman times, as mentioned before. The door thresholds were usually made of a single piece of stone. There also existed, however, as in antiquity, timber thresholds, though mostly in buildings that had timber reinforcements¹⁶. The reveals of openings were usually made of simple masonry. Door lintels (Fig. 3) were made of timber, stone or a combination thereof. Over these lintels stood arches, whose span could be smaller, equal to, or rarely larger than that of the door opening and which functioned as relieving arches. Sometimes these arches were sealed either with marble or gypsum frameworks and functioned as lighting-windows. Other times, the windows were sealed with masonry panels (tympana), usually placed on the exterior side, thus forming blind arches. The blind arches over church doors were usually painted, and are often mentioned in bibliography as overhead shrines¹⁷. In many cases also the door openings did not have horizontal lintels, so that the bearing arches remained visible behind the doorframe (Fig. 3β).

In this type of door the revolution of the, usually two door folds, which opened up towards the interior along the width of the wall (Fig. 1Γ), was effected by means of the common antique manner, of an integral axle that fit in mortises opened in the threshold (Fig. 4) and lintel (Fig. 5) of the opening. Alternately, mostly in the case of inset doorframes, these mortises were opened in the threshold and the properly recessed lintel of the doorframe. When the opening did not have a horizontal lintel, the axle fit in mortises in the recessed doorframe lintel, or in a continuous timber or stone beam, or in a wooden or iron pivot positioned behind it¹⁸ (Fig. 3β, 6).

I have yet to come across a Byzantine door that follows the usual post-Byzantine and recent “traditional” architectural type, where the door folds were attached, via iron pivots and hinges, to a four-sided, wooden door-case positioned behind a door-frame that was formed on the external side of the wall (Fig. 7).

Some particular, singular variations of this type of door are, one where the doorframe has a lintel but no doorjambs¹⁹ (Fig. 8), and one where there were doorjambs, but no lintel. There are known examples of this second variation, where the doorjambs of the doorframe were directly joined with the wooden lintel through an appropriate, diagonal cut²⁰ (Fig. 9).

¹⁶ On the reinforcement of masonry with timber see: Mamaloukos 2005, 14, with older bibliography.

¹⁷ See Bouras and Boura 2002, 413.

¹⁸ The use of pivots, usually made of stone, is more often found in gates of forts (as, for example, in the gate of the initial precinct of the maritime fort of Mandraki near the Monastery of Megisti Lavra, Mount Athos). In some cases, however, it is found in other buildings as well (as, for example, in the west door of the Katholikon of Hagios Nikolaos Monastery in Kambia, Boeotia (12th c.) where the slits into which the, now lost, iron pivots were attached are still visible.

¹⁹ As, for example, in the Katholikon of Hagios Dimitrios Monastery in Kypseli (Tourkopalouko), Preveza (late 13th c.), and the church of Hagia Paraskevi in Palaio Kerasovo, Preveza (16th/17th c. with 1680 wall paintings).

²⁰ As, for example, in the royal door of the Church of Hagia Theodora in Arta (mid 13th c.).

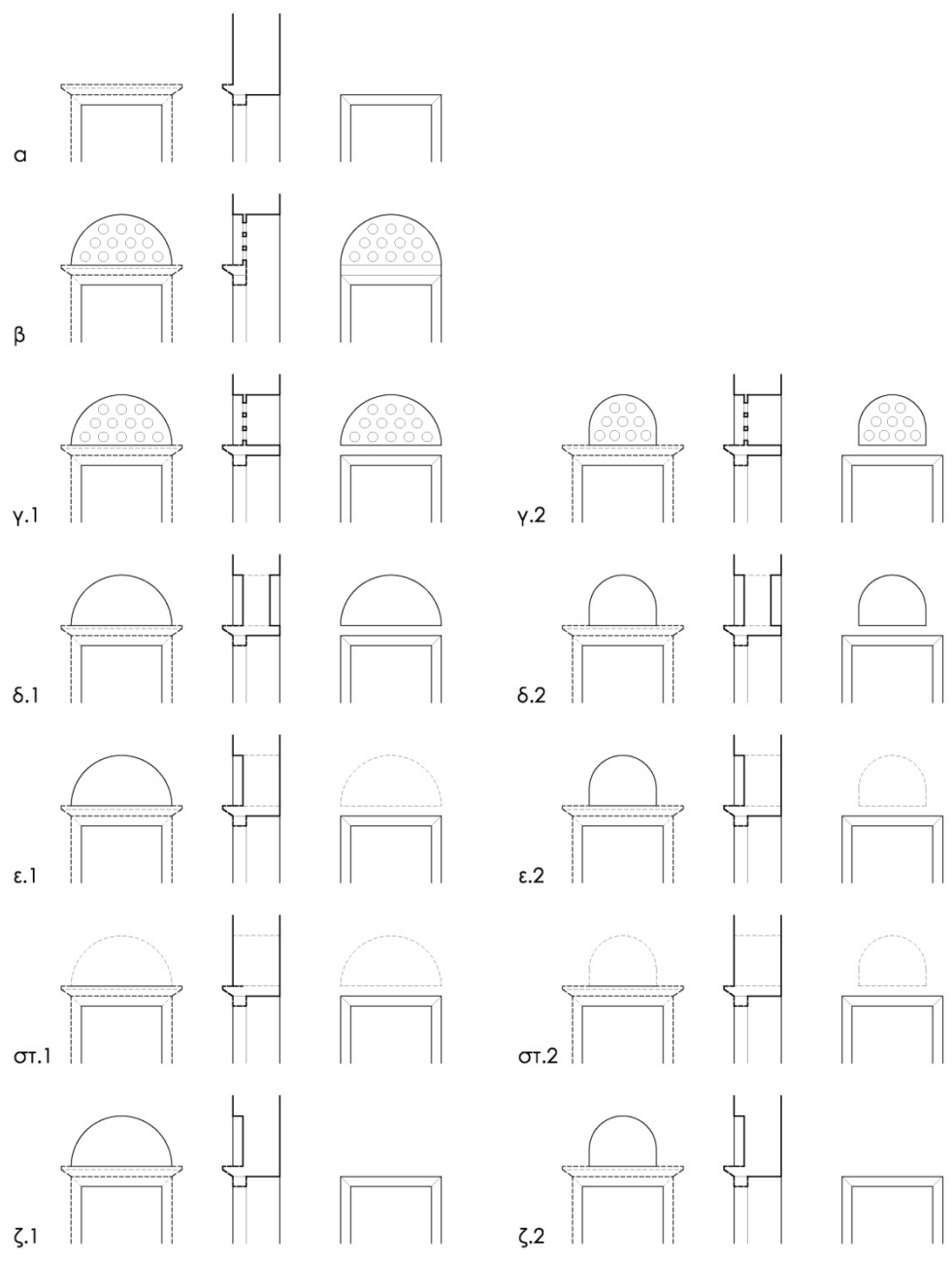

Fig. 3: Typology of door lintels and relieving arches in Byzantine architecture.



Fig. 4: Ouranoupolis, Chalkidiki. Zygos Monastery. Katholikon (c. 1000). Narthex. North door. The threshold.



Fig. 5: Athens. Church of Gorgoepekoos (12th c.). South door of the west wall of the naos. The lintel.

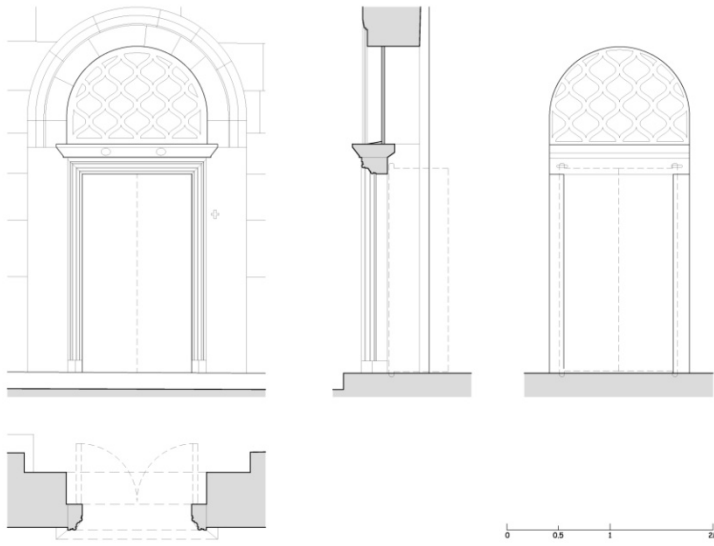

Fig. 6: Kambia, Boeotia. Hagios Nikolaos Monastery. Katholikon (12th c.). West door.

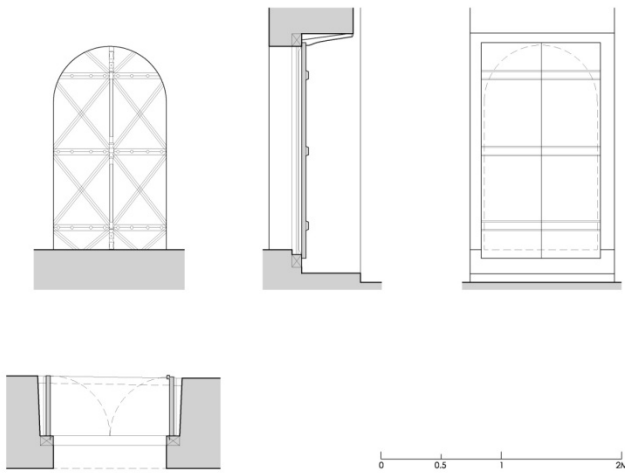

Fig. 7: Piges (Vrestenitsa), Arta. Seltsou Monastery. Katholikon (1698). Royal door.

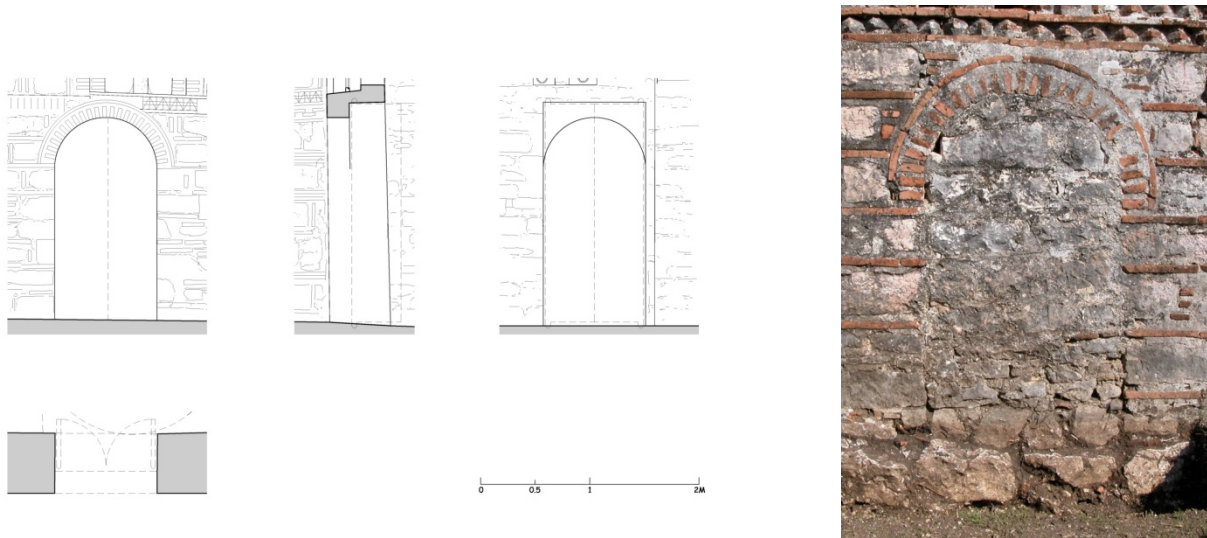

Fig. 8: Kypseli (Tourkopalouko), Preveza. Hagios Dimitrios Monastery. Katholikon (late 13th c.). South door.

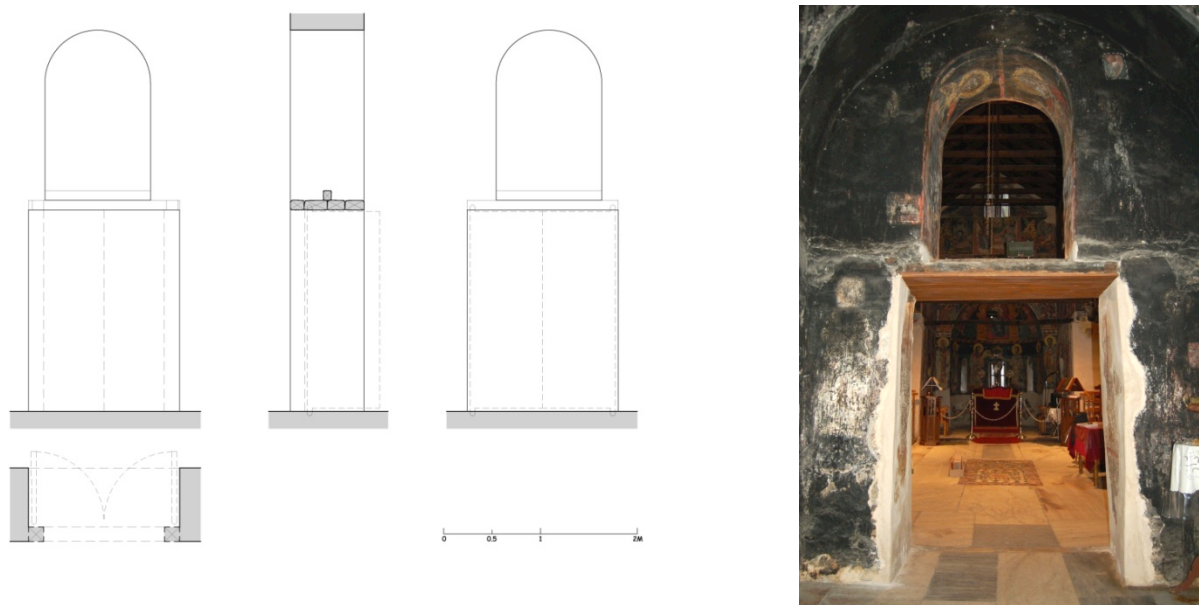

Fig. 9: Arta. Church of Hagia Theodora (mid 13th c.). Royal door.

The inset doorframes of Byzantine doors (Fig. 10) were usually made of stone—often marble—or timber. The stone ones²¹ consisted usually of two doorjambs and a lintel, which fit together at a 45° angle. The doorjambs and lintel had typical cross-sections, which differed according to re-

²¹ On the general form of marble doorframes see Bouras and Boura 2002, 414-415. On their sculptural decoration see Bouras and Boura 2002, 529-530.

gions and eras. Sometimes they had a beveled fillet section with sculpted decoration, while other times they might have a more complex cross-section, made up of ogee mouldings and ribs (Fig. 10α, β, γ). Still others had simple rectangular cross-sections²² (Fig. 10δ). Over the lintel often stood a beveled door crown or cornice with sculptural decoration. The ends of this door crown or cornice extended further on either side, and were projected onto the wall. A specially formed recess on the underside of this cornice allowed it to fit onto the door lintel (Fig. 11).

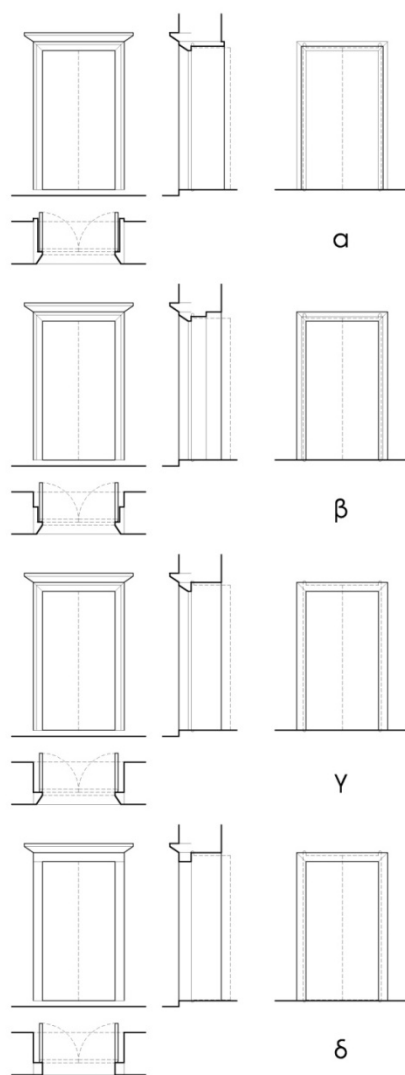

Fig. 10: Typology of inset doorframes in Byzantine architecture

²² As, for example, in the royal door of the Church of Gorgoepikoos in Athens (12th c.).

Most of the older specimens of Byzantine marble door-frames, those of Late Antiquity²³, and finally some of those belonging to lofty buildings of the mid and late Byzantine Period²⁴, the door-jambs and lintels took the form of large, wide stone slabs, with width equal to that of the jambs of the opening, and had an L-shaped cross-section. This cross-section formed the protrusion behind which the door folds were hung (Fig. 10α, 12). In the case of marble-clad walls, such door-frames were unified both morphologically and structurally with the marble cladding, forming an integral part of it. This type of door-frame closely follows the Roman way of constructing door-frames, which due to its expense and the difficulty of obtaining marble in the Mid and Late Byzantine Period, was abandoned. Thus, some of the doorframes dating back to those periods have



Fig. 11: Mount Athos. Vatopediou Monastery. Katholikon (end of 10th c.). Mesonyktikon. North door (Mamaloukos 2001, dr. 33)

doorjambs and lintels in the form of L-shaped stone slabs, but with a width smaller than the jambs of the opening, which do not completely cover the reveals (Fig. 10β). The majority of such late doorframes, however, have doorjambs and lintels of a simple linear shape, with a small cross-section, set on the exterior face of the wall (Fig. 10γ, 30A). In some instances, an effort has been made to upgrade some important openings by cladding the reveals with separate marble slabs, in addition to their marble doorframes²⁵.

²³ As, for example, in the doors of the Katholikon of Stoudiou Monastery in Constantinople (Van Millingen 1912, fig. 12-19), the Basilica B in Philippoi (Lemerle 1945, πλ.73) and the Church of Hagia Sophia in Constantinople (Antoniadis 1907, v.1, 91-92 and dr. 19). See also Orlandos 1994, 404-408 and fig. 366, 371, and 372.

²⁴ As, for example, in certain Constantinopolitan churches (Van Millingen 1912, 29, εικ.68, 75, 99).

²⁵ As, for example, in the royal door of the Katholikon of Vatopedi Monastery in Mount Athos (Mamaloukos 2001, 36 and dr. 34), and the royal door of the Katholikon of Nea Moni in Chios (Bouras 1981, 162, fig. 137, 138).

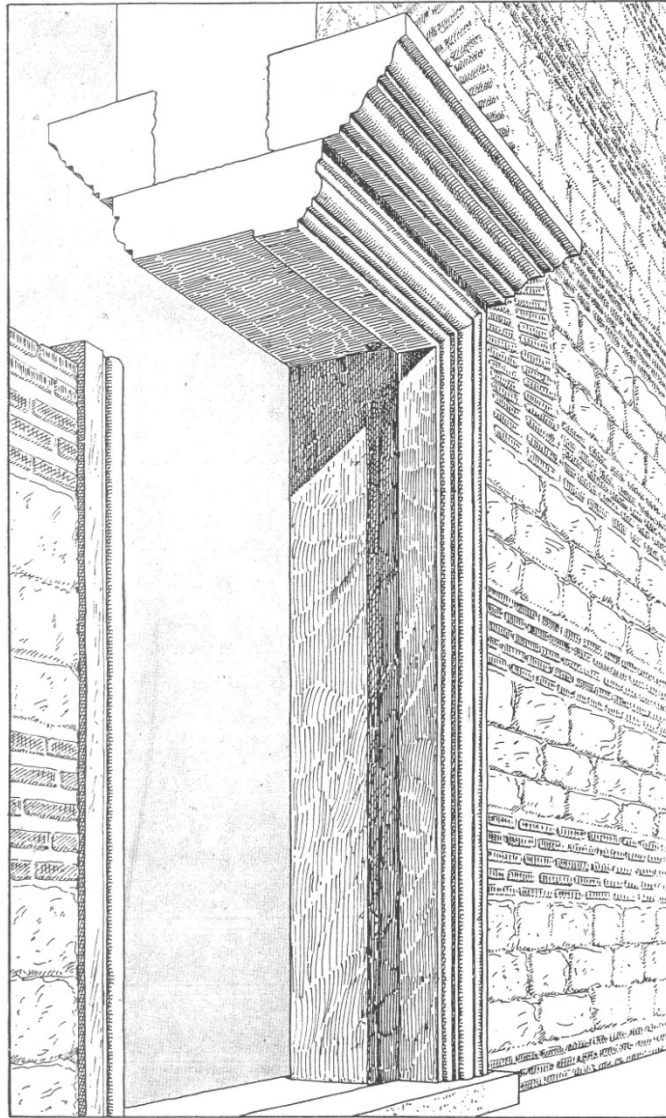

Fig. 12: Doorframe of an Early Christian Basilica (Orlandos 1994, fig. 371)

Despite the fact that naturally very few samples of timber inset Byzantine door-frames have survived, it is safe to assume that these were widespread, not just in humble structures²⁶, but continuing upon an ancient tradition, also in lofty buildings²⁷ (Fig. 13, 14). Such timber doorframes

²⁶ As, for example, in the case of the Askitirion of Prodomos, near the Monastery of Hagioi Tessarakonta, near Vassaras, Laconia (end of 13th c.?).

²⁷ Judging from their surviving fragments (mainly the thresholds and, in some cases, the lintels), timber door-frames there have been in the four doors of the significant Church of Zoodochos Pigi (Panagia Samarina) in Ellinoekklisia (Samari) in Messinia (12th c.). The door-frames of the doors of the Church of Hagia Theodora in Arta, the doors (at least the lateral ones) of the west facade of the Trapeza of Hosios Loukas Monastery, the west door of the Church of Hagios Georgios in Pournari near Mandra, Attica (13th c.?), as well as the doors of some of the cells of Dafni Monastery also seem to have been constructed of timber.

consisted of three timber pieces, in a Π -shaped structure, or four. The timber doorjambs of such Π -shaped doorframes were fixed to stone or timber thresholds via a mortise and tenon joint (Fig. 4), a common Roman era practice²⁸. Four-piece, timber frames, especially in the case of timber reinforced walls, were fixed to the openings by being fastened to the timber reinforcements, a practice also common in the more recent, so called “traditional” architecture. We must assume that the cross-sections of timber doorjambs and lintels were simple, rectangular ones. We do, however, find in certain lofty late byzantine buildings specimens of timber doorframes with complex cross-sections, and carved decoration that imitate similar marble doorframes²⁹ (Fig. 15). It is noteworthy that in some cases timber doorframes also had timber planks covering the reveals, imitating similar marble elements, as mentioned above³⁰ (Fig. 15).

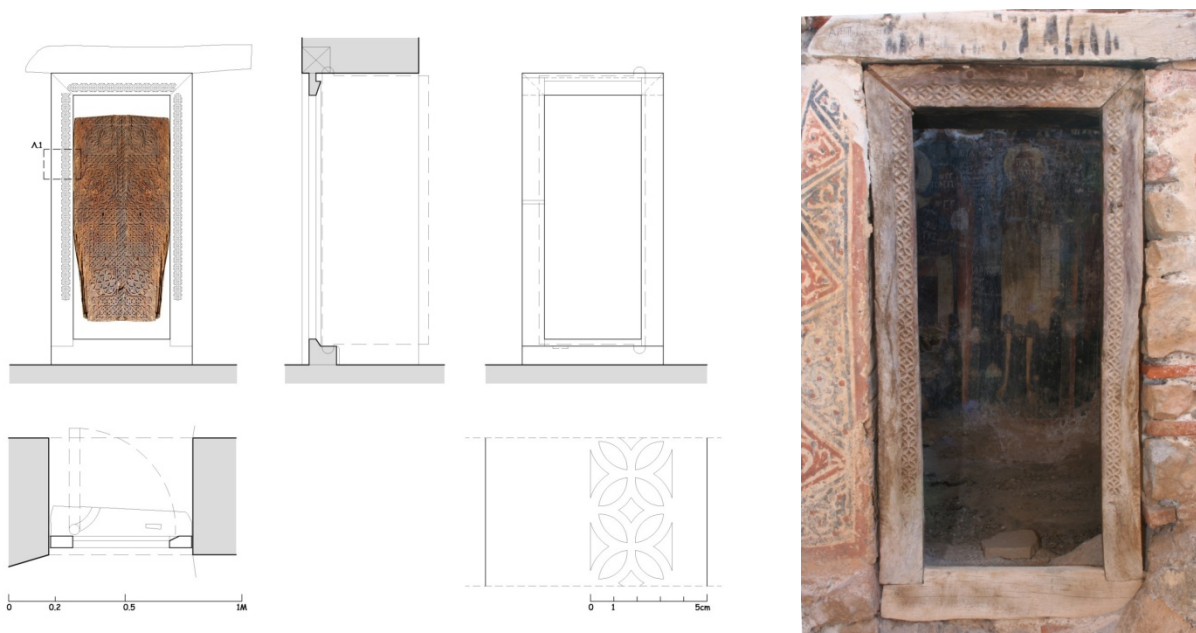

Fig. 13: Vassaras, Laconia. Monastery of Hagioi Tessarakonta. Askitirion of Prodromos (end of 13th c.?). South Door.

²⁸ Haddad 1995, 124-125, pl.62α.

²⁹ As, for example, in the royal door of the Church of Hagios Nikolaos Orfanos in Thessaloniki (early 14th c.) and the south door of the Church of Christ in Veroia (early 14th c.).

³⁰ As, for example, in the royal door of the Church of Hagios Nikolaos Orfanos in Thessaloniki (early 14th c.).

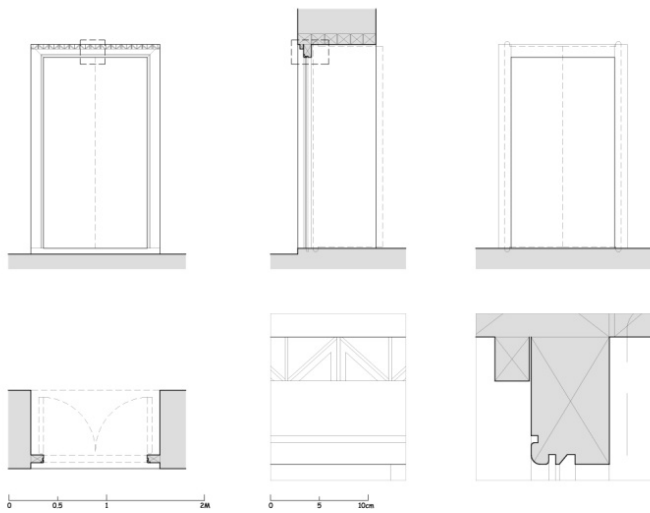

Fig. 15: Veroia. Church of Christ (early 14th c.). South door.

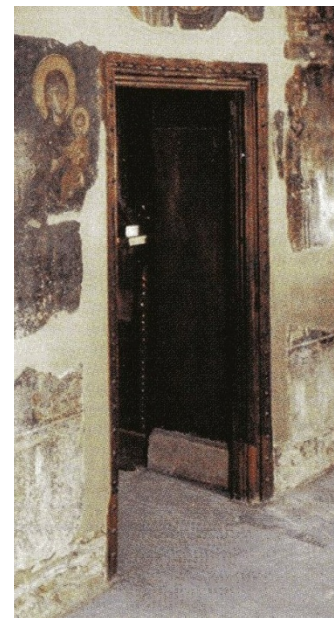
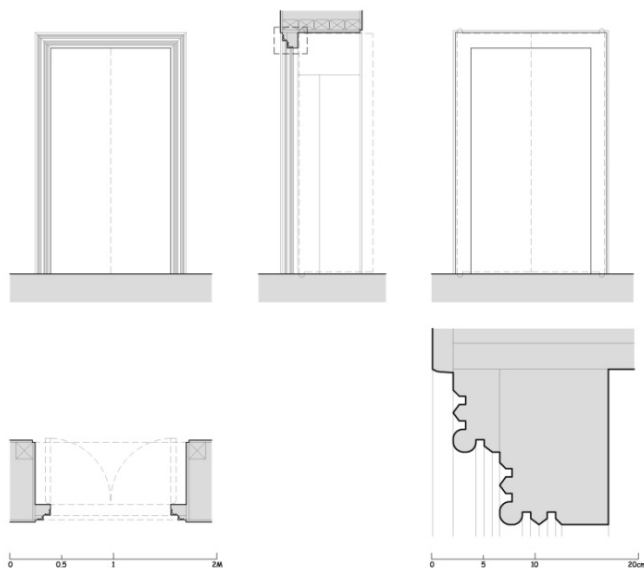

Fig. 14: Thessaloniki. Church of Hagios Nikolaos Orphanos (early 14th c.). Royal door.

The integral doorframes of Byzantine doors (Fig. 16, 17) were formed on the exterior face of the walls, and were unified with the wall masonry. The doorjambs were constructed either as part of

the wall masonry, or as specially carved, sometimes monolithic elements. In some isolated and rare cases, mainly gates with large and heavy monolithic lintels, the doorjambes were crowned with, often heavily protruding, consoles³¹ (Fig. 18). Still, a console crowning the doorjambes is a rather rare practice in Byzantine architecture, in contrast to, for example, Western European Medieval architecture³², through which this practice spread in the Late Medieval Period to the East³³. The lintels sometimes took the form of flat arches³⁴ (Fig. 19), especially in doors with a larger span. Most lintels, however, were monolithic (Fig. 20). Often they sported decorations characteristic of the region or era³⁵. Many times relieving or blind arches were constructed over the lintels, sometimes in conjunction with similar arches over the window-frames. Numerous specimens of integral doorframes survive in various Byzantine regions, dating back from Late Antiquity to the Late Byzantine Period³⁶.

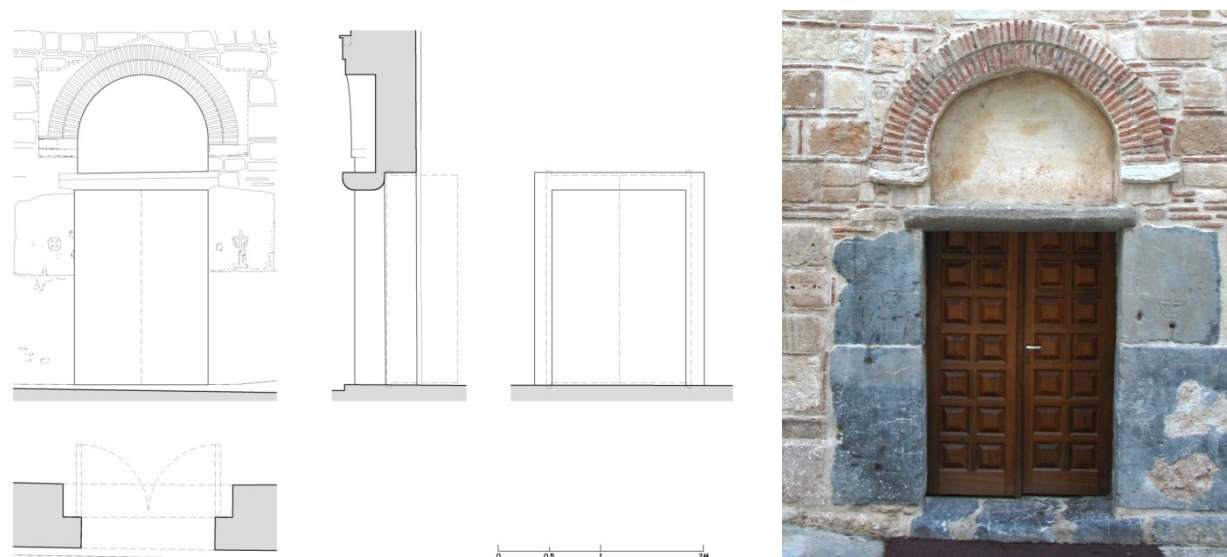

Fig. 16: Shimatari, Boeotia. Church of Hagios Ioannes Prodromos (12th c.). West door.

³¹ Meyer-Plath and Schneider 1943, pl. 7 and Krischen 1938, pl. 37.1.

³² See: Viollet le Duc 1997, fig. 52, 53, 59, 63, 69, 71, 73, 77, 79, 82, and 89.

³³ Goulaki-Voutyra 2003. See as well Filippa-Apostolou 1978, 71-72.

³⁴ As, for example, the main gate of Mount Sinai Monastery (mid 6th c.).

³⁵ A group of decorated lintels from Southern Greece, dated from the 9th/10th to the 12th/13th c., are of particular interest (see Sklavou-Mavroeidi 1982-1983 and Bouras and Boura 2002, 415-416).

³⁶ As, for example, the gate of Mount Sinai Monastery (mid 6th c.); the doors of the Church and the Palace at Qasribn-wardan in Syria (564); the west door of the Church of Hagios Ioannis Theologos in Afiklis near Apeiranthos, Naxos (8th c.?): the west door of the Church of Hagios Mamas in Dritis near Apeiranthos, Naxos (9th c.?): the door of the staircase tower in the Exonarthex of the Katholikon of Dafni Monastery, Attica (12th c.); the royal door of the Church of Hagios Nikolaos in Theves (12th/13th c.); the west door of the Church of Hagios Ioannis Prodromos in Schimatari, Boeotia (12th c.); the west door of the narthex, the royal door and the north door of the Church of Hagia Eleousa in Polydrosos (Souvala) in Phokis (12th or 13th c.); the gate of Kapikiri Ada Monastery in Latros (13th c.); and the gate of Stomio (Tsagezi) Monastery near Larissa (1492).

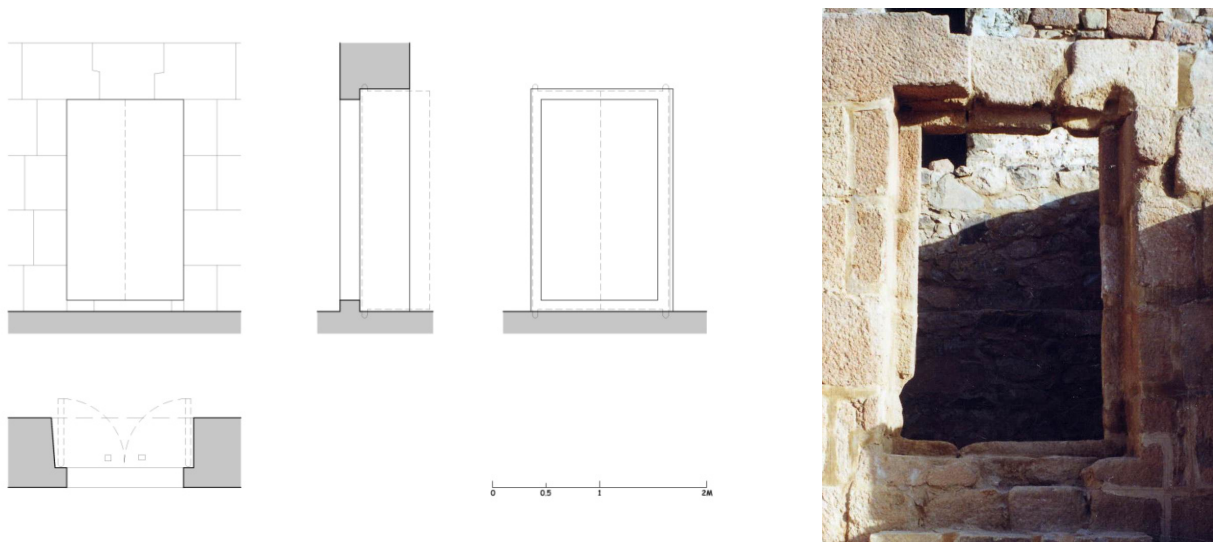

Fig. 18 Mount Sinai. Basilica of the Holy Summit. Narthex (mid 6th c.). South door (P. Koufopoulos – M. Myriantheos-Koufopoulou).



Fig. 17: Constantinople. Land Wall (early 5th c.) (Krischen 1938, pl. 37.1).

Apart from the common door type, in which a small protrusion on the exterior face of the wall formed a frame behind which were set the door folds, two more types of doors are encountered

in Byzantine architecture. These two types, despite being relatively widespread in various regions and eras, have not yet been studied, and are virtually unmentioned in the bibliography.

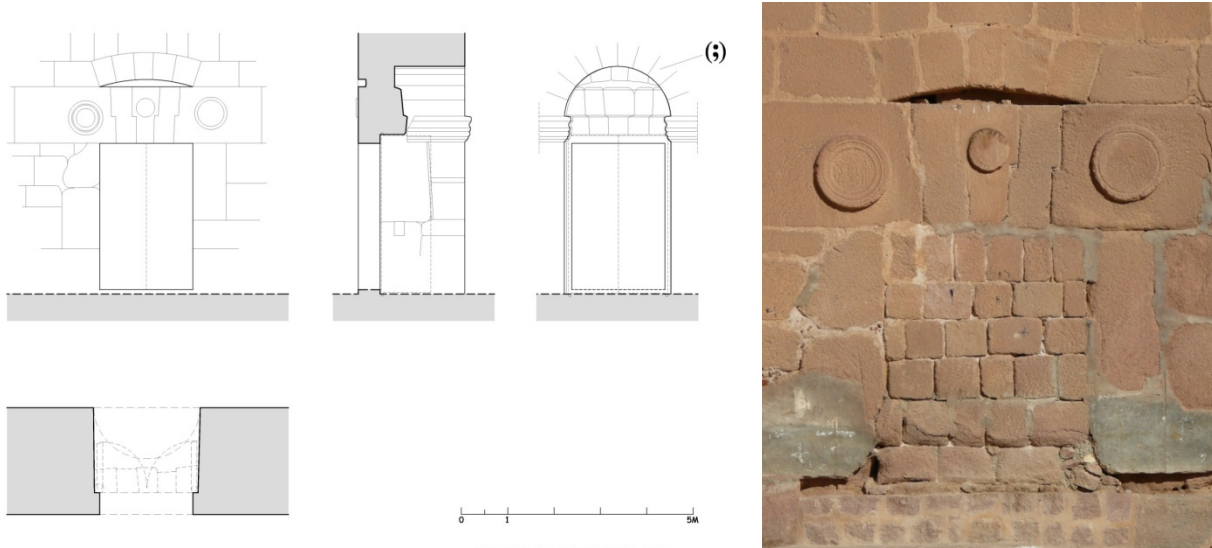

Fig. 19: Mount Sinai. Monastery of Hagia Aikaterini. Main Gate (mid 6th c.) (P. Koufopoulos – M. Myriantheos-Koufopoulou).

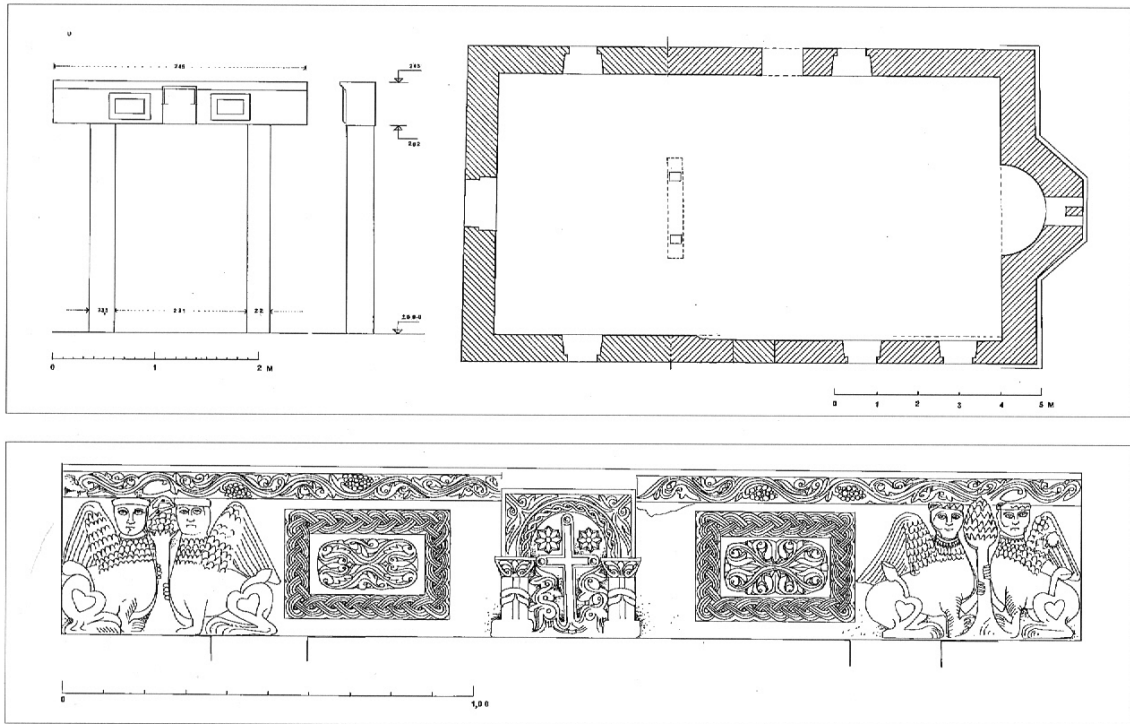

Fig. 20: Theves. Church of Hagios Nikolaos (12th c.). Royal door (Bouras – Boura 2001, figs.162, 163).

The first of those two types (Fig. 1A) is known to me from a specimen dating back to the 6th century³⁷ (Fig. 21). Doors of this type consist of a simple opening, reveals perpendicular to the wall faces, doorjambes of simple masonry or monolithic elements, standing on a threshold, and a flat lintel. The door folds were placed on the interior and revolved 180°, resting open on the interior walls. They were supported and hinged in the typical antique manner already described.

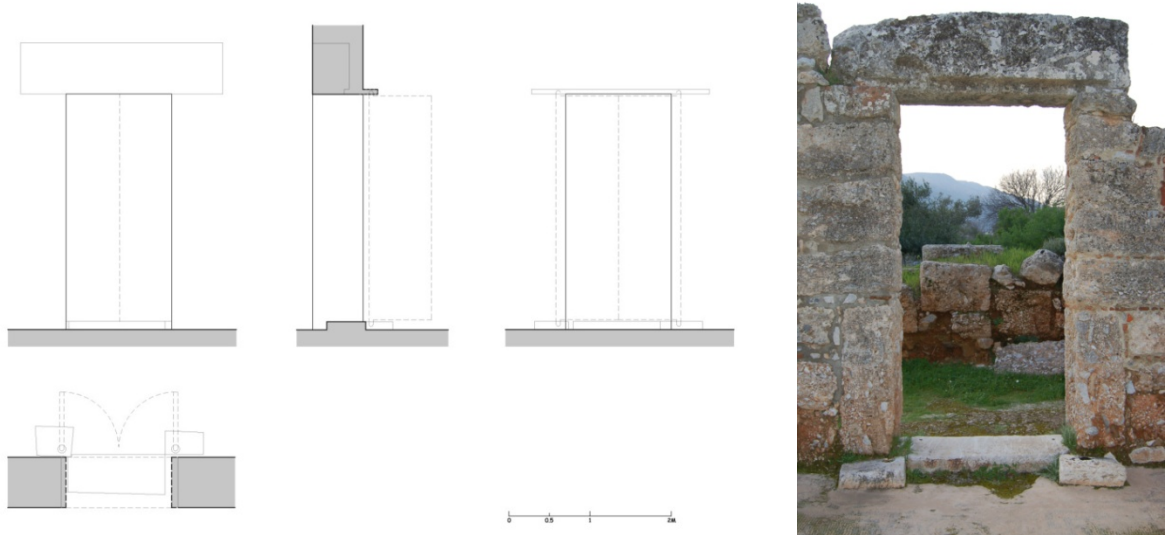

Fig. 22: Kalymnos. Vathy. Basilica of Taxiarchis in Empolas (6th c.). Royal door (J. Stavropoulos).

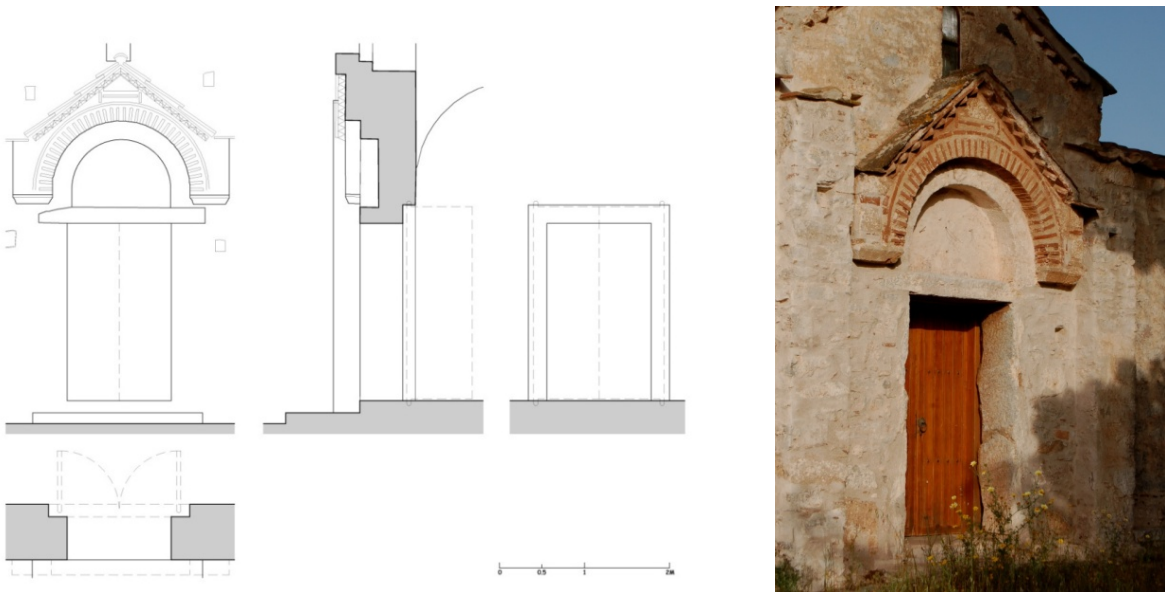

Fig. 21: Koropi, Attica. Church of the Transfiguration of Our Lord (late 10th c.). West door (St. Melissou).

³⁷ The unpublished royal door of Taxiarchis basilica in Embolas, Vathy, Kalymnos (on the monument see Karabatsos 1994, 317-322, Kollias 1994, 27-28, Koutelas 1998, 123-125).

Doors of the second type (Fig. 1B), examples of which have been for the time being located in Attika³⁸ (Fig. 22), consist of a simple opening with reveals perpendicular to the wall faces, and a shallow recess formed on the interior wall face, into which fit the door folds, supported and hinged by means of an integral axle, inserted into mortises in the threshold and lintel. One must note here a difficulty in discerning between a type B and the just described type Γ door, when the width of the recess is almost equal to that of the protrusion. A variation of this type has been encountered on the doors of some early churches on Naxos island³⁹ (Fig. 23), and some “megalithic” churches in Mani, both primitive in style and with a very small door height (often not more than 1m)⁴⁰, whose doorframe had a recess only on the lintel, while the door-jamb formed flat reveals perpendicular to the wall faces⁴¹. It is interesting that such archaic doorframes in Mani had blind arches on the exterior, constructed with well-cut stones. In such cases, these isolated elements must be traced back to the formal architecture of the period, and were used to highlight the doorway, and the accordingly the whole edifice, which otherwise was devoid of any other morphological element. Such isolated morphological elements were, however, constructed in an improvisational and haphazard manner, and resulted in types that today can be categorized as hybrids⁴². A particular group of Mani doors consists of certain doors with arched openings, and a

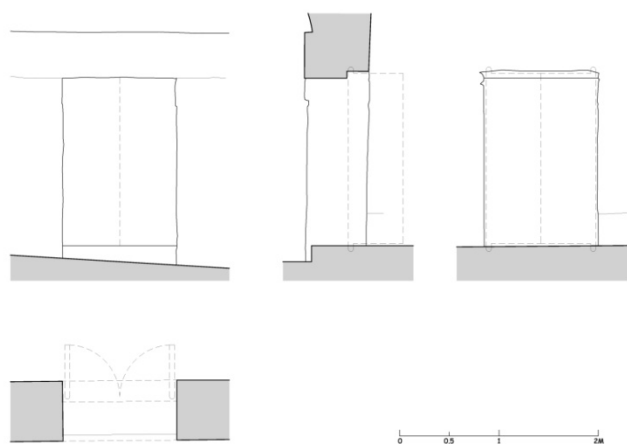

Fig. 23: Apeiranthos, Naxos. Church of Hagia Kyriaki in Kalloni (first half of 9th c.). West door (Kl. Aslanides).

³⁸ To this type belong: the south door of the Chapels of the Askitirio in Spilia Pentelis (10th c.), the west door of the Church of the Transfiguration of Our Lord in Koropi, Attica (late 10th c.), the south door of the Katholikon of Kaisariani monastery (12th c.), and the west door of the Church of Gorgoepikoos in Athens (12th c.).

³⁹ Examples from Naxos were provided by Klimis Aslanidis, who studies the medieval church architecture on the island for his doctoral thesis.

⁴⁰ Numerous photographs of examples from Mani were provided by Aggeliki Mexia, who studies the medieval churches of the area for her doctoral thesis.

⁴¹ To this type belong, for example: the west door of the Church of Hagia Kyriaki in Kalloni near Apeiranthos, Naxos, and the west door of the Church of Hagios Dimitrios in Keria, Mani.

⁴² To this type appears to belong, for example: the west and south doors of the Church of Hagios Nikolaos in Gle-zou, Mani (12th c.) and the south door of the Church of Hagioi Theodoroi in Kalou, Mani (12th c.).

lintel placed in the center of the wall width, often higher than the springing of the arch. A tympanon was formed over the lintel, while sometimes behind it there was a wooden horizontal element/lintel with mortises for the support of the door folds⁴³ (Fig. 24). Still, further research is required to fully comprehend the form and function of these doors.

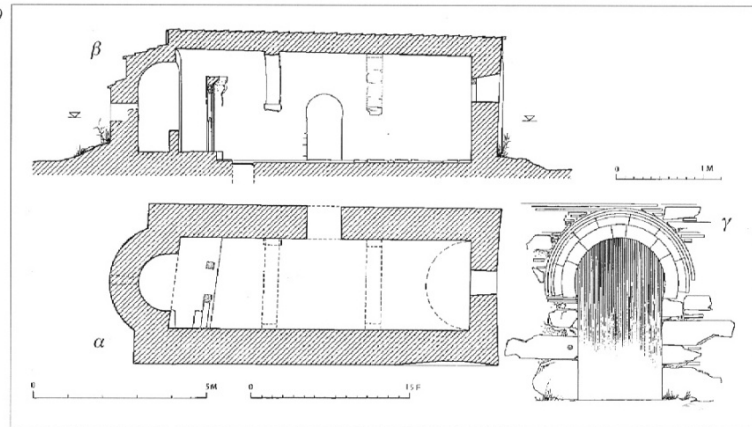

Fig. 25: Kafiona, Mani. Church of Hagioi Theodoroi (12th c.). South Door (Bouras and Boura 2001, fig. 199 and Aggeliki Mexia).

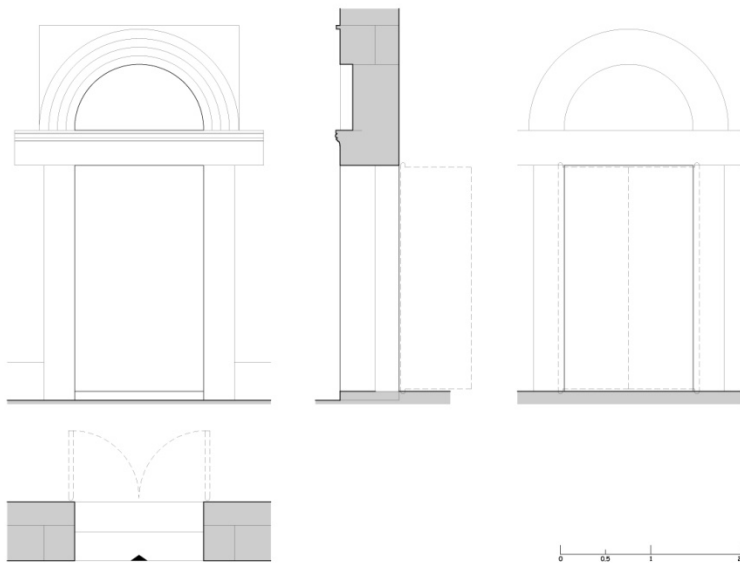

Fig. 24: Athens. Church of Gorgoepekoos (12th c.). West door

The two aforementioned Byzantine door types clearly follow the general form of types A and B, the two earlier types, of ancient Greek and Roman architecture that were described earlier in this

⁴³ To this type appears to belong, for example: the west door of the Church of Faneromeni in Dryalos, Mani (12th c.), the south door of the Church of Hagios Nikolaos in Glezou, Mani (12th c.), and the south door of the Church of Hagioi Theodoroi in Kafiona, Mani (12th c.).

study. The most well known examples of these types are generally early⁴⁴. Still, examples of these types can be encountered at least up to the 12th century⁴⁵ (Fig. 25).

Despite A. Orlandos' correct observation that the morphology of Byzantine door-frames rarely, and then only in earlier samples, follows the antique tradition with door-jambs with an Ionic order cross-section, a frieze, and cornice with or without corbels⁴⁶, a thorough study of Byzantine doors proves that their design followed the basic tenets of ancient Greek and Roman architecture.

Hence, in the integral or inset doorframe lintels that had carved decorations turning 45° onto the doorjambs, one can identify a development of the ancient Ionic order doors⁴⁷ (Fig. 26). On the other hand in doorframes where the lintel extended past the doorjambs, resembling corbels, one can identify a development of ancient Doric order doors⁴⁸ (Fig. 27).

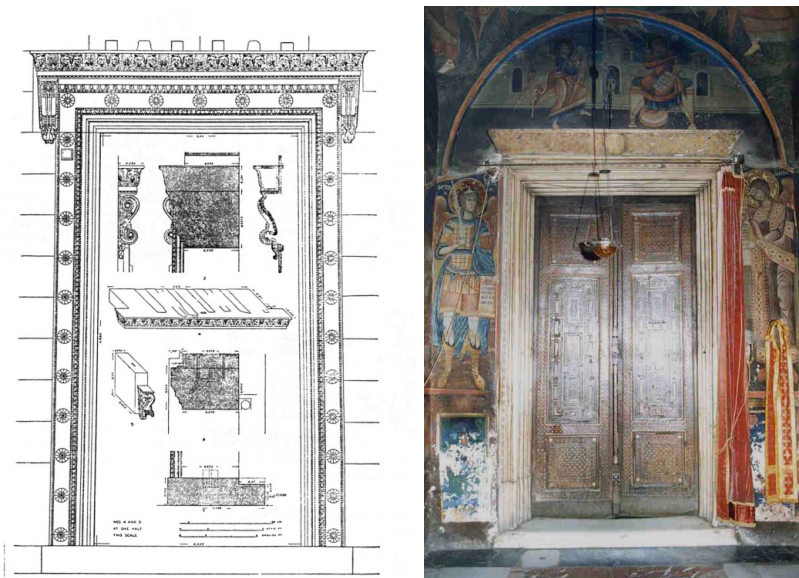

Fig. 26 A and B: The evolution of the Ionic order doorway. A: Athens. Acropolis. Erechtheion. North door. B: Mount Athos. Vatopediou Monastery. Katholikon (end of 10th c.). Royal Door.

Byzantine architecture exhibits all three aforementioned door types in various regions and time periods, with variations on individual elements. With respect to the regional and time dissemination of these types, one can at first note that it correlates with the variations in building materials and construction methods common throughout Byzantine architecture⁴⁹. Integral door-frames are prevalent in regions and periods in which the practice of carving on the masonry elements themselves

was developed, for example in Syria and eastern Asia Minor during Late Antiquity, and in Greece during the 12th and 13th century. It seems, however, that inset doorframes were constructed simultaneously along with integral doorframes, with regard to the kind of building, the availability of building materials, and the local construction methods, but also according to influence

⁴⁴ As, for example, the doors of the churches of Naxos (8th/9th c.), the Chapels of the Askitirio in Spilia Pentelis (10th c.), and the west door of the Church of the Transfiguration of Our Lord in Koropi, Attica (late 10th c.).

⁴⁵ As, for example, the north door of the Katholikon of Kaisariani Monastery (12th c.) and the west door of the Church of Gorgoepikoos in Athens (12th c.).

⁴⁶ Orlandos 1994, 405.

⁴⁷ On the form and development of Ionic Order doors see: Haddad 1995, 11, 24-29.

⁴⁸ On the form and development of Doric Order doors see: Haddad 1995, 10, 15-23.

⁴⁹ See Bouras 1994, 61.

from other areas. It is very interesting that in some cases different types of doors can be found in the same period, the same region, even the same building. For example, the Theodosian Walls of Constantinople (first half of the 5th century) have type Γ gates both with integral and inset door-frames⁵⁰. In the Basilica of Taxiarchis in Empola, Vathy, on Kalymnos Island the main entrance is a type A door, while the south entrance of the church is a type A door with a wooden, inset door-frame. Finally, in the Middle Byzantine Period, in the architecture of the Helladic region, type Γ doors prevail, in both integral and inset variations, with a preference for the latter. One can, however, also find type B doors. In some cases, again, two types of doors can be found in the same building. In the Askitirion of the Penteli Cave Church complex, (10th c.?) the south entrance is a type B door, while the western one was probably a type A with an integral, wooden doorframe. In the Katholikon of Kaisiariani Monastery (12th c.) the north entrance was a type B door, while the three entrances on the west wall were type Γ with inset, marble doorframes. Lastly, in the church of Gorgoepikoos in Athens (12th c.) the west entrance is a type B, if not type A door, while the rest type Γ with inset, marble door-frames, of which the north and two side ones were typical specimens of the type, while the main entrance door-frame an atypical variation.

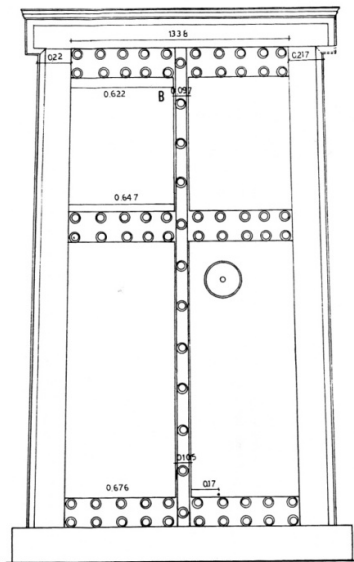

Fig. 27 A and B: The evolution of the Doric Order Doorway. A: Vergina, Macedonia. Macedonian Tomb (the so called “Romaioi” Tomb”). Door. B: Athens. Church of Gorgoepikoos (12th c.). West door.

As for the changes that were affected by various outside influences on the morphology and the general form, but even on preferences for certain door types, probably the most typical example are some Balkan regions, like Southern Greece or Serbia. Either because they remained long under Frankish rule⁵¹, or because they cultivated cultural ties with the West⁵², they were greatly influenced by

Western European architecture. The type that prevailed in these areas during the Late Byzantine Period, and later during Ottoman rule, but without replacing completely all other types, was a type Γ door with an integral doorframe and certain morphological features, termed rather loosely

⁵⁰ See Krischen 1938, tab. 14 and Meyer-Plath and Schneider 1943, 37-49, tab. 7 and 17-18.

⁵¹ Such as the southern Greece, most of the Aegean islands, the Ionian islands, Crete and Cyprus.

⁵² Such as medieval Serbia.

“opening with an inset frame”⁵³. The doors of this group took the form of an opening with reveals perpendicular to the walls, or sometimes widening towards the interior, with either a horizontal wooden or stone lintel⁵⁴ (Fig. 28), or a stone, usually, segmental arch⁵⁵ (Fig. 29). The exterior side of the opening had a rather thin stone frame, with either horizontal or arched – in some cases pointed – lintel⁵⁶ (Fig. 30). In many instances, the similarities with Gothic architecture, in morphology and construction, are striking⁵⁷ (Fig. 31).

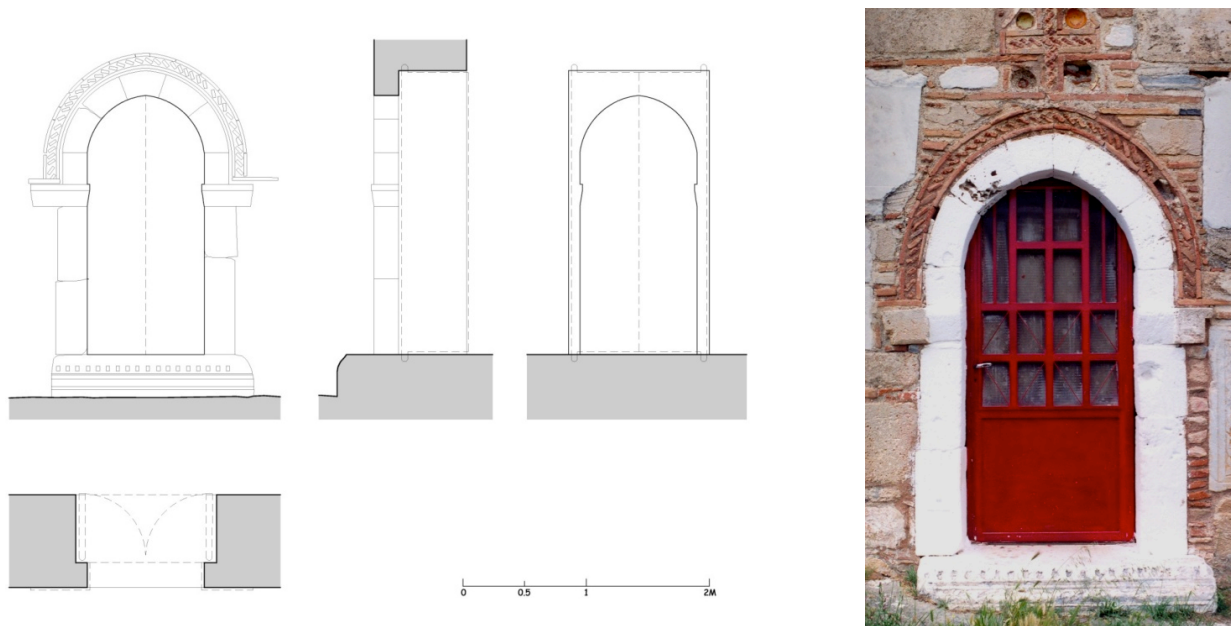

Fig. 28: Ano Vatheia, Euboea. Church of Panagitsa (early 14th c.). South door

⁵³ Mamaloukos 2004, 135; id. 2005, 12-13; id. 2007, n. 69.

⁵⁴ As, for example, the door of the Church of Hagios Ioannis Kalyvitis in Leimonia, Salamis.

⁵⁵ As, for example, the now sealed south door of the Chapel of Omorfi Ekklesia in Galatsi, Attica and the door of the Church of the Transfiguration of Our Lord in Aianteio (Moulki), Salamis.

⁵⁶ For a systematic presentation of the various door types of this group see: Athanasoulis 2006, 478-482.

⁵⁷ On doors in Western European medieval architecture see: Viollet le Duc 1997, v.3, 314-468. On the spread of Gothic morphology door-frames in the Latin ruled Eastern Mediterranean see: Athanasoulis 2006, 478-482; Borboudakis 2007; and Gratziou 2010, 55-76.

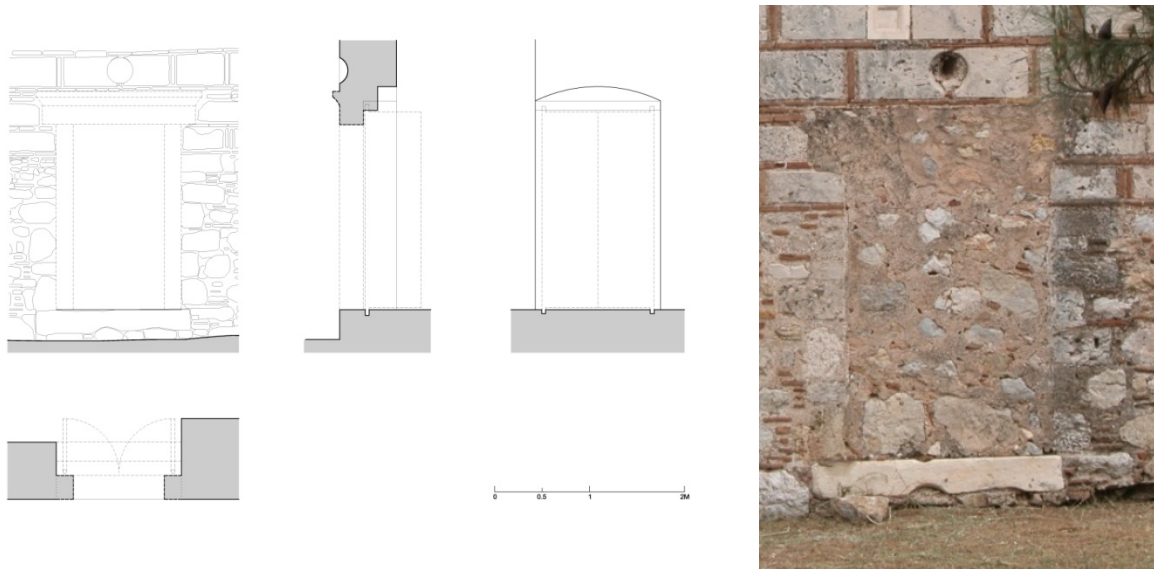

Fig. 30: Galatsi, Attica. Church of Hagios Georgios (Omorphi Ekklesia). Chapel (c.1300). South Door.

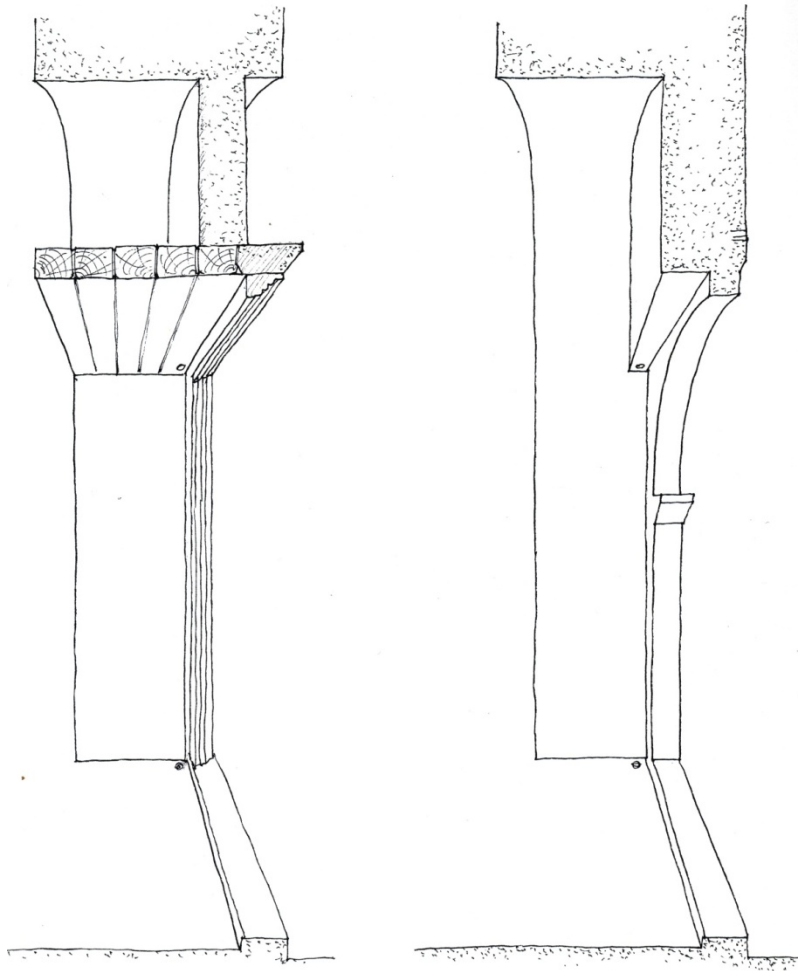

Fig. 29: A: Door with an inset frame. B: Door with an integral frame (Mamaloukos 2007, 69)

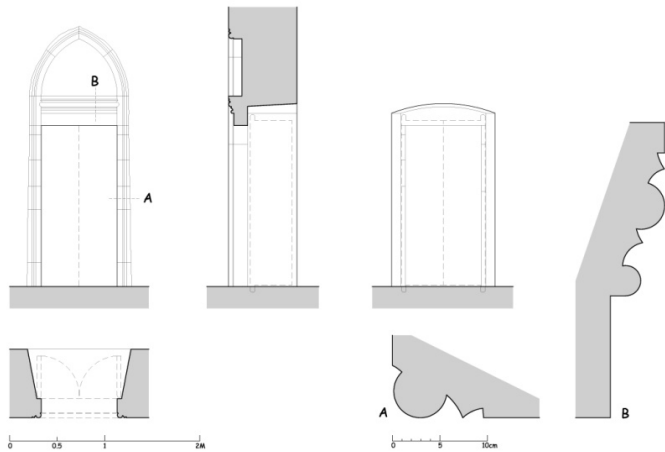

Fig. 32: Viannos, Crete. Hagia Moni. Katholikon (14th c.). South door.

V. Two kinds of windows are found in Byzantine architecture: lean-out windows (*paraktyptikai thyridai*) and lighting windows (*fotistikai thyridai*)⁵⁸. The first (Fig. 32), which existed in civic buildings but also in religious buildings of some merit, and of which we have few surviving samples, had opening window casements that provided lighting and ventilation, and allowed view to the exterior.



Fig. 31: Constantinople. Tekfur Saray (mid. 14th c.). Lean-out window (photo. N. Fotopoulos).

The second kind of window (Fig. 33), which was more prevalent, was sealed with framework⁵⁹ and provided only lighting to the interior. In the case of humble buildings or spaces that housed secondary functions or served defensive purposes, essential lighting and se-

⁵⁸ On lean-out and lighting windows see Orlandos 1937, 67-68.

⁵⁹ On window frameworks see Ousterhout 1999, 151-156.



Fig. 34: Hosios Lukas Monastery, Boeotia. Katholikon (early 11th c.). Lighting-windows

curity were provided, as in antiquity, via lighting slits, which were named arrow slits when they served defensive purposes. These light-holes, or lighting slits, had no permanent frameworks, but must have been sealed crudely with other elements (planks, braches, rags or even shoddy masonry), as in seen in similar cases in “traditional” architecture.

The general form and development of lean-out windows in Byzantine architecture differs little from that of doors. The window openings had reveals perpendicular to the wall faces, and a narrow protrusion on the exterior face, behind which the window casements were set, supported and pivoted in a manner similar to doors (Fig. 34). The window-jambs and sills were usually made of simple masonry. The lintels were, as they were for doors, horizontal lintels made of wood, stone, or both materials. Just as in the case of doors, above the lintels stood relieving or blind arches.

The protrusion around the window-frame could be either integral or inset. Variations of this type of windows, examples of which have been spotted by A. Orlandos in Mystras, have been named

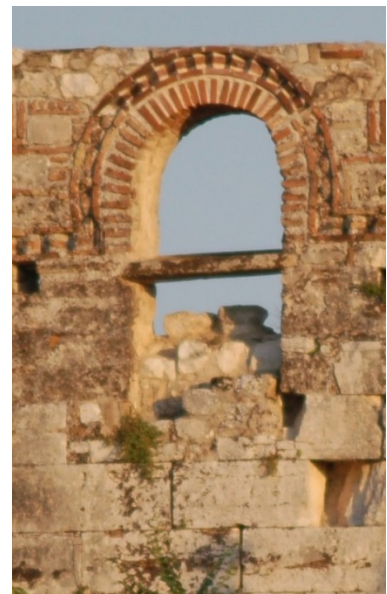
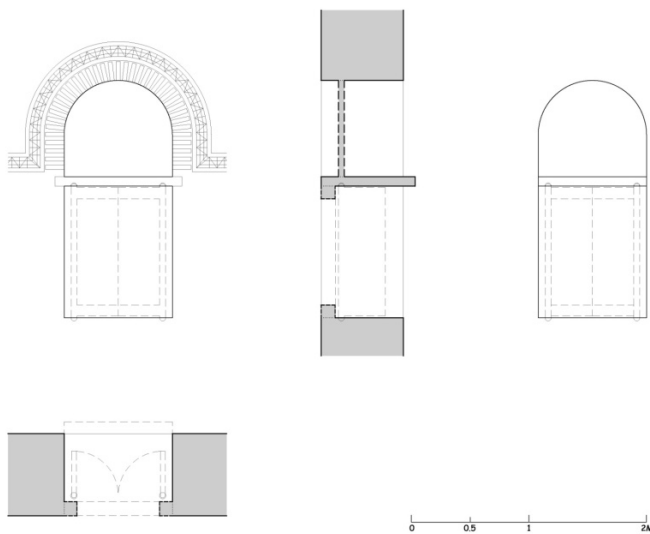

Fig. 33: Palaiopolis, Corfu. Church of Panagia Neratzicha (11th c. (?). North Window

“windows with a recessed tympanon”⁶⁰ (Fig. 35). They were arched windows with a wooden lintel recessed from the exterior face, over which stood a tympanon. Their general design resembles that of the arched doors from Mani, already described above. The exact way they functioned is currently unknown.

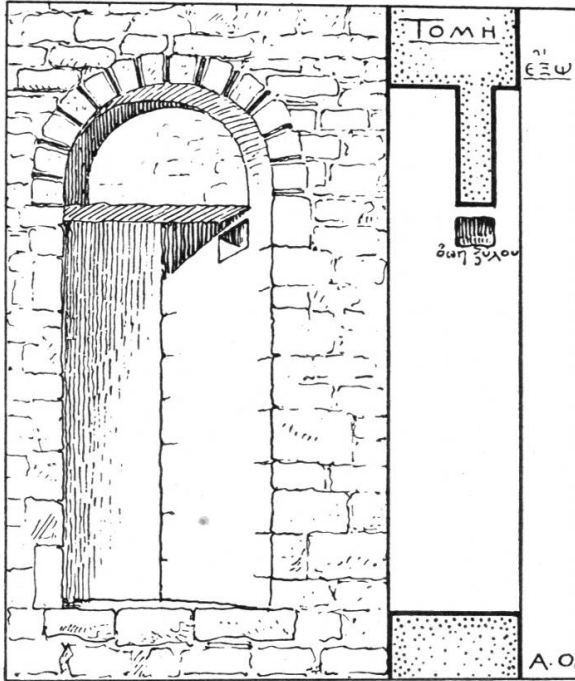

Fig. 35: Mystras. House Y. Window (Orlandos 1937, fig.58).

relieving or blind arches stood over the lintels. These arches were either associated with the lintels or not.

The inset window-frames were of stone—usually marble—or timber. The first were very similar to the doorframes that have already been discussed⁶¹ (Fig. 32). Often the window-frames had a vertical element running down their middle, with a cross-section similar to that of the jambs, onto which the two window-casements latched closed⁶² (Fig. 36). These windows could be named double-light windows, just like similar windows in antiquity. The wooden window-frames seem to have been attached to the openings in ways similar to that of the respective door types⁶³ (Fig. 34, 36).

The integral window-frames of Byzantine lean-out windows were, as in similar doors, shaped on the exterior face of the walls, incorporated into the masonry. The window-jambs were either constructed of the same masonry as the walls, or consisted of specially carved, sometimes monolithic, elements. Here as well, re-

⁶⁰ Orlandos 1937, 69 fig.58.

⁶¹ As, for example, the windows of the complex openings in the Katholikon of Vatopedi Monastery in Mount Athos (Mamaloukos 2001, 37-38, 39, 71-72, 85, 187-188), and the Katholikon of Hosios Loukas Monastery (Schultz and Barnsley 1901, pl. 1-3, 5-8, 16, 17), the upper floor windows of Tekfur Saray in Constantinople (Ousterhout 1991, fig. 10), the towards the interior of the main church window of the north gallery in the Katholikon of Chora Monastery in Constantinople (Van Millingen 1912, fig. 100) and the Exonarthex windows of Kilise Camii in Constantinople (Van Millingen 1912, fig. 84-87).

⁶² As, for example, the windows of the five-light complex opening in the Liti of the Katholikon of Vatopedi Monastery (Mamaloukos 2001, 71-72, pl. 49, fig. 214, 247, 217, 249, 223, 253, 226, 255).

⁶³ As, for example, in the north wall window of the Church of Panagia Neratzicha in Palaiopolis in Corfu (on the church see Vocotopoulos 1970, 151-152, pl.1).

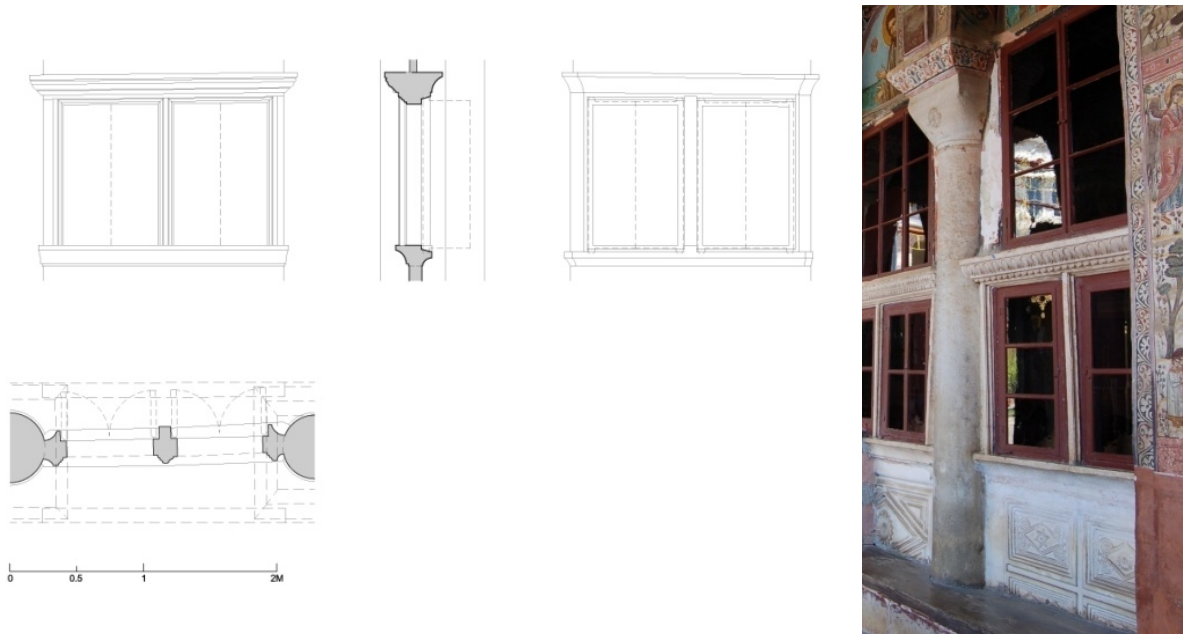

Fig. 36: Mount Athos. Vatopediou Monastery. Katholikon. Liti (first half of 11th c.). Five light complex opening. Window.

The lighting windows of Byzantine architecture were usually arched single-light, double-light, triple-light, or multiple-light windows. They belonged either to the “arcade” type or to the “complex” or “grouped” type⁶⁴. The window reveals were perpendicular to the wall faces (even though this was not always true for conches) and the arched lobes extended throughout the whole width of the walls. The lobes were separated by mullions that were usually shaped like small double-columns (Fig. 37A). We rarely come across lighting windows with other shapes, like rectangles⁶⁵, crosses⁶⁶ or circular ones⁶⁷ in Byzantine architecture. The openings of lighting windows were sealed with fixed frameworks made of marble, gypsum-mortar, metal or wood⁶⁸.

The study of windows in Byzantine architecture presents great interest when one comes across complex openings i.e. both those which fill large arched openings⁶⁹ and those which fill the spac-

⁶⁴ Megaw 1931-1932, 120-121; Vocotopoulos 1969, 163; Bouras and Boura 2002, 419.

⁶⁵ As, for example, the windows of the Church and the Palace in Qasr-ibn-wardan in Syria (564); the Basilica of Taxiarchis in Embolas; Vathy; Kalymnos; some of the secondary windows of the Church of Katapoliani on the Island of Paros; the sanctuary apse window of the Church of Ai-Stratigos in Ano Boularioi, Mesa Mani; the south facade window of the Church of Taxiarchis on Mount Elanion, Aegina; and the windows of most churches of Naxos, such as the Church of Hagios Isidoros in Rachi, Tragaia whose windows are of considerable dimensions. On rectangular windows in Byzantine church architecture, see Vocotopoulos 1992, 164, fig. 2.

⁶⁶ As, for example, those on the pediments of the Katholikon of Mount Sinai Monastery, the churches of Hagia Kyriaki in Apeiranthos, and Panagia Damiotissa in Kaloxylos, Naxos (Vocotopoulos 1992, 155).

⁶⁷ On circular windows in Byzantine church architecture see: Vocotopoulos 1992, 203, fig. 2.

⁶⁸ On window frameworks see Ousterhout 1999, 151-156.

⁶⁹ As, for example, the complex openings of the Church of Hagia Sofia in Constantinople (Antoniadis 1907, v.1, 92-93 and fig. 23).

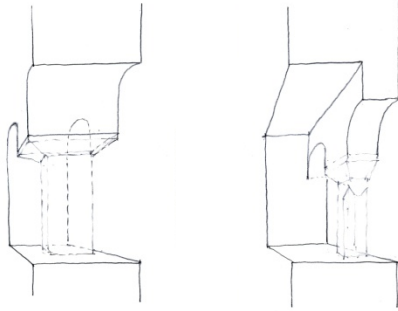

Fig. 37: A: Window with lobes extended throughout the whole width of the walls. B: Window with an integral frame (Mamaloukos 2007, 69)

es between double-light, triple-light and multiple-light openings⁷⁰ (Fig. 38, 39). Complex openings are found in important buildings from Late Antiquity⁷¹, during the Middle⁷² and Late Byzantine Period⁷³, and later, during Post-Byzantine⁷⁴ and Late Ottoman Periods, even up to the late 19th century, in lofty buildings—mainly, but not solely churches—that follow the Byzantine tradition⁷⁵. The patterns for complex openings were derived from Roman architecture, and in the case of Middle to Late Byzantine Period, they are characteristic of the so-called School of Constantinople⁷⁶. Examples of complex openings are encountered in various regions of the Byzantine empire, both in important

and non-important, sometimes even humble, buildings, predominantly on exonarthexes⁷⁷, but also in churches mainly on the tympana of the cross arms of cross-in-square type churches⁷⁸, and seem to be associated with an effort to improve the quality of interior spaces by better lighting, according to the intentions and means of the patrons. Complex openings included both lean-out and lighting windows, over marble parapets, and often doors too.

⁷⁰ As, for example, those of the Katholikon of Vatopedi Monastery in Mount Athos (Mamaloukos 2001, 187-188 and fig. 37, 38, 39, 49, 51, 55).

⁷¹ Characteristic examples of complex openings dating to late antiquity are those on the west facade of the narthex of the Katholikon in Stoudiou Monastery (Van Millingen 1912, fig. 12, 13, 16) and the numerous large openings on the facades of Hagia Sofia in Constantinople (Antoniadis 1907, v.1, 92-93, 128-129, fig. 23, 181, and pl. KA'-KΔ').

⁷² Examples of complex openings of the Middle Byzantine Period are those of the Katholikon of Vatopedi Monastery in Mount Athos (Mamaloukos 2001, 187-188 and fig. 37, 38, 39, 49, 51, 55), the Katholikon of Hosios Loukas Monastery in Boeotia (Schultz and Barnsley 1901, pl. 1-3, 5-8, 16, 17), the exonarthex of the Katholikon of Dafni Monastery in Attica (Stikas 1962-1963, 6, 11, 12, 13, 15, 16), (Stikas 1962-1963, 6, 11, 12, 13, 15, 16), the Katholike Ecclesia of Ainos (Enez) (Mamaloukos 2005-2006, 4-6 and fig. 1-8), and the Katholikon of Hagios Nikolaos Monastery in Kambia, Boeotia (Schultz and Barnsley 1901, pl. 56.2, 57, 58, 60).

⁷³ Examples of complex openings of the Late Byzantine Period are those of the Exonarthex of Kilise Cami in Constantinople (Van Millingen 1912, fig. 84-87) and the Katholikon of Chilandari Monastery in Mount Athos (Ćurčić 1987, fig. 12-15).

⁷⁴ Examples of complex openings of the Post-Byzantine Period are those of the Katholikon of Doxeiariou Monastery in Mount Athos, built shortly after mid 16th c. (Touliatos 2009, dr. 6-17).

⁷⁵ Examples of complex openings of the Late Ottoman Period are those of the Katholika of Filotheou (1746), Xeropotamou (1761-1763), Xenofontos (1809-1819) and Hagiou Pavlou (1839-1844) monasteries in Mount Athos.

⁷⁶ Millet 1916, 206; Vocotopoulos 1981, 559, 561.

⁷⁷ As, for example, in the Church of Kapnikarea in Athens (Bouras 2010, 196-202). For the spaces of byzantine architecture that can be characterized as “closed exonarthexes,” see Mamaloukos 2001, 157-159.

⁷⁸ As, for example, in the Church of Hagioi Anargyroi of Psyris in Athens (Bouras 2010, 142-144) and a group of Post-Byzantine churches in Attica, where at least some of the double-light openings on their facades must have initially been sealed with complex openings (Stoufi-Poulimenou 2007, 62, 277).

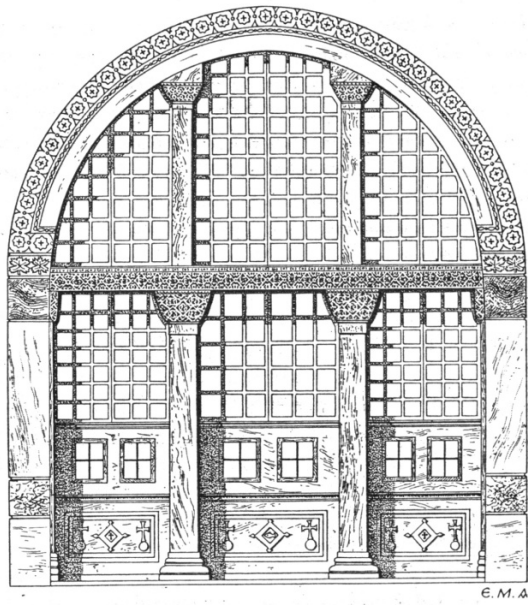

Fig. 39: Constantinople. Church of Hagia Sophia (mid 6th c.). Complex openings (Antoniadis 1907, dr. 23).

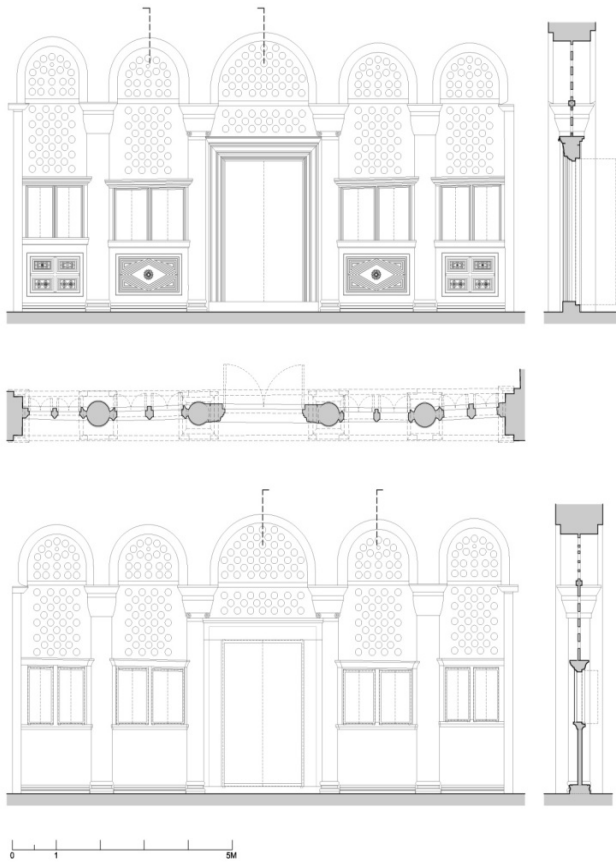

Fig. 38: Mount Athos. Vatopediou Monastery. Katholikon. Liti (first half of 11th c.). Fivelight complex opening.

The general form of windows with lobes extended throughout the whole width of the walls

seems to remain strikingly unchanged from Late Antiquity to the 19th century, in most Byzantine regions⁷⁹. This consistency is noted mostly in lighting windows. In areas, however, that were influenced by Western European Architecture, the design of windows and the construction and morphology in general, bore heavy influence, as did that of doors. The most important change in window design is the spread of a type of window, mostly lean-out but also lighting, with an integral frame⁸⁰, which had the form of an opening with its reveals either perpendicular to the wall faces or widening towards the interior (Fig. 37B). The windows of this type were either rectangular, with horizontal, wooden or stone lintels (mainly in small windows⁸¹), or arched, with a full or a segmental arch⁸². An integral, rather small stone frame, was formed on the exterior face, rectangular or arched, single-light, double-light or with pointed arch lobes⁸³. It must be noted that lighting windows' frames often did not have window-jambes. The morphological and structural similarities with Western European Medieval, Romanesque, and Gothic windows are indeed striking⁸⁴ (Fig. 40).

Considerable changes were also made in the construction and morphology of openings, which in many cases led to the complete loss of the initial unity of form. Still this window-frame retained, albeit in mannerist style, the basic characteristics of the old morphology⁸⁵ (Fig. 41).

VI. Upon a comprehensive study of the general design, construction and morphology of Byzantine architecture doors and windows, one can draw a number of conclusions, which are also valid for other aspects of construction and morphology in Byzantine architecture in general:

1. The continuity of construction technology from Antiquity into the Byzantine Period is unquestionable.

⁷⁹ As, for example, in Mount Athos, where many samples attest to this continuity.

⁸⁰ See: Mamaloukos 2004, 135; id. 2005, 12-13; id. 2007, 69 and fig. 2.

⁸¹ As, for example, the windows of the churches of Panagitsa in Ano Vatheia, Euboea (early 14th c.) and Odedetria in Spilies, Euboea (early 14th c.).

⁸² As, for example, in the double-light windows on the tympanon of the transverse cross arm and the drum of the narthex dome of the Church of Hagios Dimitrios in Chania Avlonariou in Euboea (late 13th c.).

⁸³ As, for example, in the double-light windows on the tympanon of the transverse cross arm and the drum of the narthex dome of Hagios Dimitrios church in Chania Avlonariou (late 13th c.) and the double-light windows of House Y in Mystras (Orlandos 1937, fig.59).

⁸⁴ On windows in Western European Medieval Architecture, see Viollet le Duc 1997, v.2, 365-419, and particularly for casement windows 400-419 and fig. 29-33 and 35-42. Fine specimens of such windows in Greece survive in many Frankish monuments, such as the castles of Chlemoutsi and Katytaina (Athanasoulis 2006, 314). On the spread of Gothic morphology windows in Crete, but also in the rest of Frankish Ruled East, see Borboudakis 2007 and Gratziou 2010, 55-76.

⁸⁵ We find fine specimens of this practice in a group of churches of Southern Greece, such as for example the sanctuary apse window of the Church of Odegetria in Spilies, Euboea, where lobes pseudo-arches are carved on the lintel surface.

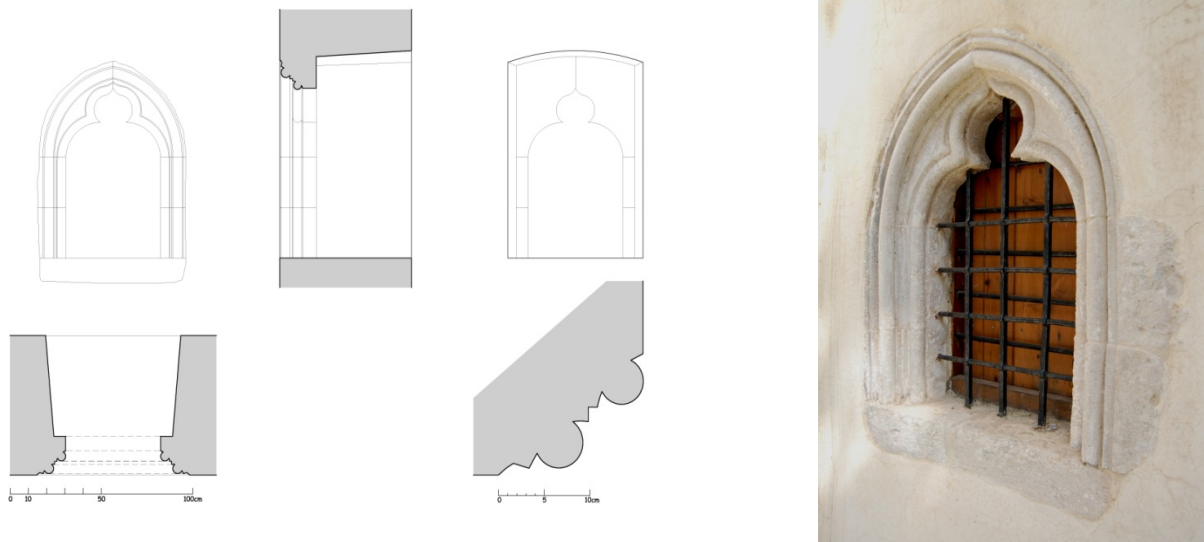

Fig. 41: Viannos, Crete. Hagia Moni. Katholikon (14th c.). South window.

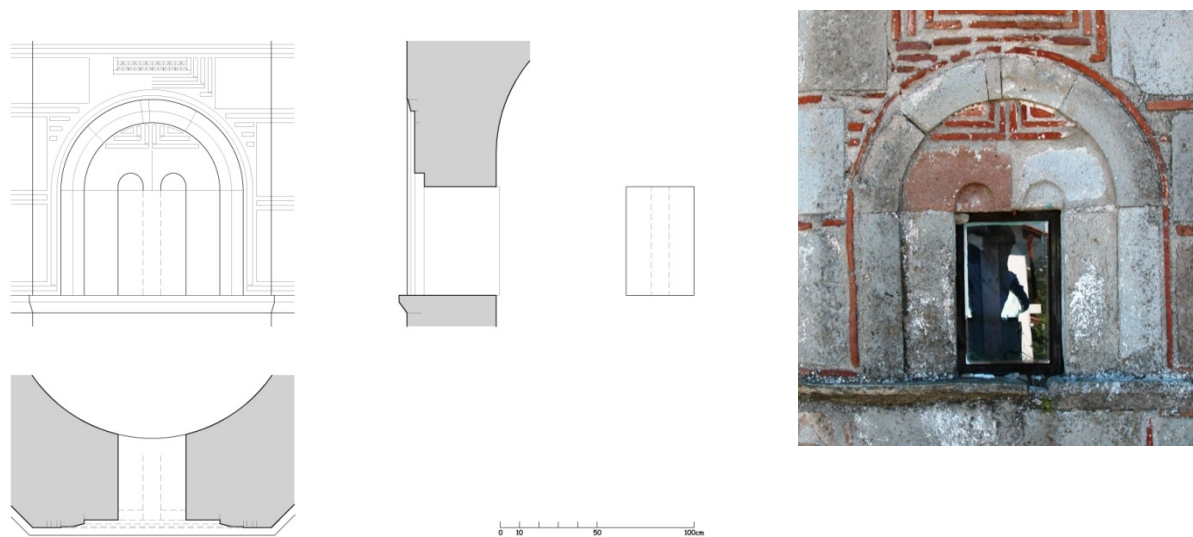

Fig. 40: Spilies, Euboea. Church of Hodegetria (early 14th c.). Bema window.

2. One observes a striking persistence of construction types and forms from Roman, Hellenistic, and even Classical Antiquity, well into Byzantine, and Post-Byzantine Periods (and sometimes even up to the present).

3. It is notable that various old and new types of door and window openings were used simultaneously. Even though it has not been possible to quantify the extent to which old construction types were used parallel to new types, the phenomenon is not negligible.

4. Slow developments with small, incremental changes on several aspects of construction, and consequently morphology, are observed. These are mostly attributable to the general and gradual

deterioration of building technology, and the lack of materials. These two phenomena are characteristic of Byzantine architecture when compared to high Roman architecture.

5. It is observed that in some buildings of a humble or even primitive type, for example some churches in Mani, an effort was made to highlight the old-type openings with the use of elements of formal architecture, resulting in new hybrid types.

6. Deeper and more conspicuous changes are observed during the Post-Byzantine Period, and are attributed to the influence on Byzantine architecture of already established Western European Architecture. This influence was affected by the organized building programs of Frankish rulers, and through social ties that developed during that time in the wider area of the east Mediterranean. The practical benefits of the new type of openings, together with improvements in stone cutting and the decreasing use of marble, led to the substitution of older opening types, mostly doors but also often lean-out windows, for new ones. Still, the old types did not completely disappear, but carried on, albeit on buildings of a more popular type. Afterwards, during the 15th and up to the early 19th century, such changes in the design and constructions of openings are reduced, though they still occur in overall building morphology.

Based on present research, one can safely point out that the design of windows and doors offers a fertile field for further study of already known patterns of influence of Byzantine architecture, be they internal, as the development of the so called “Helladic School” in the 11th and 12th century, or external, as is the influence on Byzantine architecture of Arabic initially, and later on, of western European and formal Ottoman architecture.

Bibliography

- Antoniadis, E. 1907. Έκφρασις της Αγίας Σοφίας (Athens).
- Athanasoulis, D. 2006. Η ναοδομία στην Επισκοπή Ωλένης κατά την μέση και την ύστερη βυζαντινή περίοδο (Ph.D. diss., Univ. of Aristotle University of Thessaloniki).
- Borboudakis, M. 2007. “Θυρώματα και παράθυρα σε εκκλησίες της Κρήτης (τέλος 14^{ου}–μέσα 15^{ου} αιώνα),” in: O. Gratziou (ed.) 2007. Γλυπτική και λιθοξοϊκή στη λατινική Ανατολή. 13^{ος}–17^{ος} αι. (Rethymno), 60-89.
- Bouras, Ch. 1981. Η Νέα Μονή της Χίου. Ιστορία και Αρχιτεκτονική (Athens).
- Bouras, Ch. 1994. Ιστορία της Αρχιτεκτονικής, ν.2. Αρχιτεκτονική στο Βυζάντιο, το Ισλάμ και την Δυτική Ευρώπη κατά τον Μεσαίωνα (Athens).
- Bouras, Ch. 2010. Βυζαντινή Αθήνα, 10^{ος}-12^{ος} αι (Athens).
- Bouras, Ch. 1964. Les portes et les fenêtres en architecture byzantine (Thèse 3ème cycle (polycopie)) (Paris).
- Bouras, Ch. 1975. “The byzantine bronze doors of the Great Lavra Monastery on Mount Athos,” JÖB 24, 229-250.
- Bouras, Ch. 1989-1990. “The Olympiotissa wood-carved doors, reconsidered,” DChAE 15, 27-32.
- Bouras, Ch. and L. Boura 2002. Η Ελλαδική Ναοδομία κατά τον 12^ο αιώνα (Athens).
- Ćurčić, Sl. 1987. Hilandar Monastery: An archive of Architectural Drawings, Sketches and Photographs (Princeton).
- Dimitrakos, D. Μέγα Λεξικόν όλης της Ελληνικής Γλώσσης (Athens).
- Drandakis, N. 2002. Βυζαντινά γλυπτά της Μάνης (Athens).
- Filippa-Apostolou, M. 1978. Το Κάστρο της Αντιπάρου. Συμβολή στη μελέτη των οχυρωμένων μεσαιωνικών οικισμών του Αιγαίου (Athens).
- Ginouvès R., Martin R. et al. 1992. Dictionnaire Méthodique de l' Architecture Grecque et Romaine, Tome 2, Eléments constructifs : Supports, couvertures, aménagements intérieurs (Roma)
- Goulaki-Voutyra, A. 2003. “Δείγματα μαρμαρογλυπτικής του Αιγαίου στο Μουσείο Μπενάκη,” Μουσείο Μπενάκη 2, 111-123.

- Gratziou, O. 2007. “Αναζητώντας τη γλυπτική των Βενετών στην Κρήτη,” in O. Gratziou (ed.) 2007. Γλυπτική και λιθοξοϊκή στη λατινική Ανατολή. 13^{ος}–17^{ος} αι. (Rethymno), 180-195.
- Gratziou, O. 2010. Η Κρήτη στην Ύστερη Μεσαιωνική Εποχή. Η μαρτυρία της εκκλησιαστικής αρχιτεκτονικής (Heraklion).
- Haddad, N. 1995. Θύρες και παράθυρα στην ελληνιστική και ρωμαϊκή αρχιτεκτονική του ελλαδικού χώρου (Ph.D. diss., Univ. of Aristotle University of Thessaloniki).
- Iacobini, A. 2007. “Arte e tecnologia bizantina nel Mediterraneo. Le porte bronze dell’XI-XII secolo,” in A. C. Quintavalle (ed.), Medioevo mediterraneo : l'Occidente, Bisanzio e l'Islam : atti del convegno internazionale di studi, Parma, 21-25 settembre 2004 (Milano) 496-510.
- Iacobini, A. 2009. Le porte del Paradiso. Arte e tecnologia bizantina tra Italia e Mediterraneo (Roma).
- Karabatsos, V. 1994. “The Early Christian Churches of Kalymnos and Telendos,” in Κάλυμνος. Ελληνορθόδοξος ορισμός του Αιγαίου (Athens), 259-362.
- Kollias, E. 1994. “Σχεδιάσμα της αρχαιολογίας και της τέχνης της Καλύμνου από τα παλαιοχριστιανικά χρόνια μέχρι το τέλος της Ιπποτοκρατίας (1522),” in Κάλυμνος. Ελληνορθόδοξος ορισμός του Αιγαίου, (Athens), 23-50.
- Korres M. 1994. Μελέτη αποκαταστάσεως του Παρθενώνος, v.4 (Athens).
- Koutelas, M. 1998. Κάλυμνος. Ιστορία – Αρχαιολογικοί Χώροι – Μνημεία (Kalymnos).
- Krischen, Fr. 1938. Die Landmauer von Konstantinopel, T.1, Zeichnerische Wiederherstellung mit Begleitendem Text (Berlin).
- Lemerle, P. 1945. Philippes et la Macédoine orientale à l'époque chrétienne et byzantine: recherches d'histoire et d'archéologie (Paris).
- Mamaloukos, S. 1991. “Ο πυλώνας της Μονής Αγίου Ιωάννου του Κυνηγού στον Υμηττό,” in Αρμός. Τιμητικός Τόμος στον Καθηγητή Ν. Κ. Μουτσόπουλο για τα 25 χρόνια πνευματικής του προσφοράς στο Πανεπιστήμιο 2 (Thessaloniki), 1107-1119.
- Mamaloukos, S. 2001. Το Καθολικό της Μονής Βατοπεδίου. Ιστορία και Αρχιτεκτονική (Athens).
- Mamaloukos, S. 2004. “Ο ναός του Αγίου Πολυκάρπου στην Τανάγρα (Μπράτσι) Βοιωτίας,” DChAE 25, 127-139.

- Mamaloukos, S. 2005. “Η οικοδομική τεχνολογία στο Βυζάντιο,” *Αρχαιολογία και Τέχνες* 96 (September 2005), 8-17 (with a summary in English : Building Technology in Byzantium, 17).
- Mamaloukos, S. 2005-2006. “Συμπληρωματικά στοιχεία για την αρχιτεκτονική της Καθολικής Εκκλησίας (Φατίχ Τζαμί) της Αίνου / Additional notes on the architecture of the “Katholike Ekklesia” (Fatih Camii) at Ainos (Enez),” *Περί Θράκης* 5, 11-39.
- Mamaloukos, S. 2007. ‘Παρατηρήσεις στη διαμόρφωση των ανοιγμάτων των θυρών και των παραθύρων στη βυζαντινή αρχιτεκτονική,’ in *Εικοστό Έβδομο Συμπόσιο Βυζαντινής και Μεταβυζαντινής Αρχαιολογίας και Τέχνης. Πρόγραμμα και Περιλήψεις Εισηγήσεων και Ανακοινώσεων* (Athens) 68-69.
- Marinou, G. 2007. “Δυτικά γλυπτά στοιχεία στο Μυστρά,” in O. Gratziou (ed.) 2007. *Γλυπτική και λιθοξοική στη λατινική Ανατολή. 13^{ος}-17^{ος} αι. (Rethymno)*, 48-59.
- Matthiae G. 1971. *Le Porte Bronzee Byzantine in Italia* (Roma).
- Megaw, A.H.S. 1931-1932. “The Chronology of Some Middle-Byzantine Churches,” *BSA* 32, 90-130.
- Meyer-Plath B. and Schneider A. M. 1943. *Die Landmauer von Konstantinopel, T.2, Aufnahme, Beschreibung und Geschichte* (Berlin).
- Millet, G. 1916. *L’ école grecque dans l’ architecture byzantine* (Paris).
- Nikonanos, N. 1979. *Βυζαντινοί ναοί της Θεσσαλίας από το 10^ο αιώνα ως την κατάκτηση της περιοχής από τους Τούρκους το 1393. Συμβολή στη βυζαντινή αρχιτεκτονική* (Athens).
- Orlandos, A. 1937. “Τα Παλάτια και τα σπίτια του Μυστρά,” *Αρχαίον των Βυζαντινών Μνημείων της Ελλάδος* 3, 3-114.
- Orlandos, A. 1994. *Η ξυλόστεγος παλαιοχριστιανική βασιλική της Μεσογειακής λεκάνης*, (repr. of 1952-1956 edn., Athens).
- Orlandos, A. and Travlos, J. 1986. *Λεξικόν αρχαίων αρχιτεκτονικών όρων* (Athens).
- Ousterhout, R. 1991. “Constantinople, Bithynia, and Regional Developments in Later Palaeologan Architecture,” in Sl. Curcic and D. Mouriki (edd.), *The Twilight of Byzantium. Aspects of Cultural and Religious History in the Late Byzantine Empire, Papers from the Colloquium Held at Princeton University 8-9 May 1989* (Princeton), 75-110.
- Ousterhout, R. 1999. *Master Builders of Byzantium* (Princeton University Press).

- Schultz R. W. and S. H. Barnsley 1901. *The Monastery of St. Luke of Stiris, in Phokis and the Dependent Monastery of St. Nicholas in the Fields, near Skripou, in Boeotia* (London).
- Sklavou-Mavroeidi, M. 1982-1983. “Ομάδα υπερθύρων του Βυζαντινού Μουσείου,” *DChAE* 11, 99-108.
- Stikas, Eu. 1962-1963. “Στερέωσις και αποκατάστασις του Εξωνάρθηκος της Μονής Δαφνίου,” *DChAE* 3, 1-47.
- Stoufi-Poulimenou. Io. 2007. *Εκκλησίες στον κάμπο των Μεγάρων* (Athens).
- Touliatos, P. 2009. *Ιερά Μονή Δοχειαρίου Αγίου Όρους. Η αρχιτεκτονική του καθολικού και του πύργου* (Athens).
- Van Millingen, A. 1912. *Byzantine Churches in Constantinople, Their History and Architecture* (London).
- Viollet le Duc, Eu. 1997. *Dictionnaire Raisoné de l' Architecture Francaise du Xie au XVIe siècle* (2nd. edn., Paris).
- Vocotopoulos, P. 1969. “Περί την χρονολόγησιν του εν Κερκύρα ναού των Αγίων Ιάσωνος και Σωσιπάτρου,” *DChAE* 5, 149-174.
- Vocotopoulos, P. 1970. “Η βυζαντινή τέχνη στα Επτάνησα,” *Κερκυραϊκά Χρονικά* 15, 148-180.
- Vocotopoulos, P. 1981. “The Role of Constantinopolitan Architecture during the Middle and Late Byzantine Period,” *JÖB* 31/2, 551-573.
- Vocotopoulos, P. 1992. *Η Εκκλησιαστική Αρχιτεκτονική εις την Δυτικήν Στερεάν Ελλάδα και την Ήπειρον από του τέλους του 7^ο μέχρι του τέλους του 10^{ου} αιώνος* (2nd edn., Thessaloniki).
- Vocotopoulos, P. 2000. “Panagitsa. A Byzantine Chapel at Methana,” in *Λιθόστρωτον. Studien zur Byzantinischen Kunst und Geschichte. Festschrift für Marcell Restle* (Stuttgart) 313-323.