

Quiz for February 23rd 2005 - Physics 151-001 - Prof. Thomson

- 1) Consider the following circuit with two batteries as shown. *The indicated directions for each of the currents must be used. If your answer is negative, then it means that the current flows in the opposite directions.*

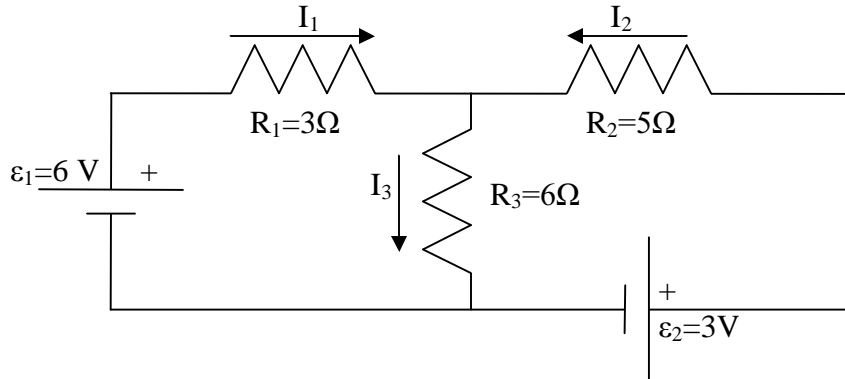

(2 pts)
(1 pt)

(1 pt)
(1 pt)

- a. Using just symbols, not numbers, write out the other two of three independent equations using Kirchoff's Rules for the above circuit. You should not solve them for this part. Put the equations in the boxes.

$$\varepsilon_1 - I_1 R_1 - I_3 R_3 = 0$$

- b. Find the remaining two of the three indicated currents in the above figure. (remember signs!)

$$I_1 =$$

$$I_2 = -1/7 \text{ A}$$

$$I_3 =$$

- c. Is the second battery with an EMF of $\varepsilon_2=3\text{V}$ **charging** or **discharging**? (circle one)
- d. How much power, P, is being dissipated as heat in all of the resistors of this circuit?

$$P =$$